

Simple and efficient PID algorithm design method for controlling first order systems with a time delay

Mohamed S. Soliman

Department of Electrical Engineering, Collage of Engineering, Taif University, P.O. Box 11099, Taif 21944, kingdom of Saudi Arabia

DOI: <https://doi.org/10.56293/IJASR.2022.5483>

IJASR 2023

VOLUME 6

ISSUE 1 JANUARY - FEBRUARY

ISSN: 2581-7876

Abstract: Many processes in industry are characterized by delay time or by slow aperiodic dynamics called lag behavior. In addition, many plants in the industry are described mathematically by higher order systems that are approximated with the lower order systems, most frequently such processes and systems are described mathematically as first-order-systems-with time-delay (FOSTD), also called first-order-plus-dead-time (FOPDT). The presence of time delays causes degradation and limitation of achieving desired performance, moreover, it can induce instability. In such cases, design of feedback control algorithm becomes difficult and tedious task.

The present work suggests an efficient, simple, linear, and easy to apply design expressions for designing continuous PID (proportional-integral-derivative) control algorithm modes to control the behavior of FOPDT systems. The design expressions are intended to overcome negative effects of time delay presence, as well as, to simplify the control algorithm design process and help designer, in easy and simple way, to get system under control with acceptable system stability, medium fastness of response and without or with minimum possible overshoot, oscillation and error.

For testing and evaluating the correctness, applicability and efficiency of the derived expressions, MATLAB/Simulink software was applied to develop refined software simulation model that simulates real life values and returns maximum needed numerical and graphical data for assessment process. In addition, various FOSTD systems' types and forms were used in the simulation model, in particular, systems with small, medium and large time constants, DC gains, and time delay, unstable systems, systems with variable delay. Furthermore, to assess the efficiency of suggested design expressions, the resulted overall system response were compared with resulted responses when two design methods were applied; worldwide known Ziegler Nichols method and MATLAB/Simulink auto-tuned PID block. Analysis of numerical and graphical testing results, show that, The designed control algorithm applying the suggested expressions can, not only simplify the design process, but also, efficient for successful in getting system under control and improving controlling plants performance, speeding up response, reduce overshoot, and minimize error, but also stabilize an unstable plants.

Keywords: Optimum control system, PID algorithm design, first order system, time delay, FOSTD, FOPDT.

1. Introduction

Modern advances in various aspects of science, including in production technologies and systems design, had led to development of a variety of new products. One of main and most influential decision, in the design process of these new products, is related to the selection, integration and design of two directly related to each another product's parts, namely; physical controller/control unit and control program/algorithm. This decision is effected by many factors, main of which are product complexity, functionality, desired performance, desired precision, efficiency and costs.

Control system is terms used to describe a system built by integrating five main elements; the physical controller/control unit, control program/algorithm, communication interfaces, sensor and actuator or physical system to be controlled. The physical controllers are classified into the following six main programmable types; PC, Microcomputer, Microcontroller, Digital signal processors (DSP), Application specific integrated circuits (ASICs)

and PLC. On the other hand, the control program/algorithm can be developed as one of the next main three forms; ON-OFF (event and/or time driven), multistep and continuous algorithms. Continuous algorithms are further categorized into many other forms; man of which include PID (proportional-integral-derivative) modes, adaptive algorithm and artificial intelligent (AI) control algorithms, that are categorized into; Genetic algorithm, Neural network, Fuzzy logic algorithm, and expert systems.

Control system design is a term used to describe control algorithm selection, design and coding process. this design process can be referred to one of the following; (a) selection of optimal control algorithm gains that will achieve desired system closed-loop response, (b) for application with artificial intelligent algorithms; designing knowledge rule base and Inference mechanism (engine) or ,finally, (c) designing and coding control program for specific controller type e.g. Microcontroller , PLC or CNC, to implement a given task or control a given physical system. [1,2].

Plants is a terms used to describe physical system or processes to be controlled. Many Plants in industry are characterized by delay time, also called transport delay, or by slow aperiodic dynamics that is also called lag behavior. In addition, many plants in the industry are described mathematically by higher order systems that are approximated with the lower order system, most frequently such systems are described mathematically as first-order-systems-with time-delay (FOSTD) that is also called first-order-plus-dead-time (FOPDT) [1,2]. Moreover, many other systems type and order are approximated as such ones. The presence of time delays causes degradation and limitation of achieving desired performance, moreover, it can induce instability. Therefore, due to the presence of time delay, design of feedback control algorithm becomes difficult and tedious task [3].

The present work is limit to process of designing continuous PID algorithm modes for application with first order system plus time delay FOPTD and systems that can be approximated as such. The main goal of this work is limited to suggesting simple, robust, efficient and easy to use, design expressions for continuous PID control algorithm modes, namely: P, PI (proportional-derivative) and PID intended for controlling the dynamics of FOPDT and systems that can be approximated as such.

The PID control algorithm and its modes are, in majority cases, considered most commonly and dominant control algorithm for controlling the dynamics of industrial applications [4]. This is due to the following facts; with first order system dynamics, PID algorithm performs very well with strength to provide perfect control over plant varied dynamic characteristics, in addition, algorithm has simple construction, ease of use and robustness, However, for some system types and cases, the algorithm will not perform as expected, such cases include; (a) the algorithm can provide marginally better control when applied for higher order systems when tight and precise control is required, (b) systems with big value of time delay, and(c) systems with light damping and oscillatory response to achieve better control over system dynamics, PID algorithm modes are designed with a compromise, such that plant is controlled to respond with acceptable both stability level and response fastness, in addition, minimum not observable overshoot, oscillations and zero or minimum possible error. based on this, suggesting new design methods and expressions for PID algorithm modes remains a highly interesting and propulsive research field (you may see also [5] and references therein), resulted in many PID algorithm design methods, expressions and patents can be found in the literature [6] based on which numerous commercial control units were developed over the last several decades. Beside the worldwide famous and applied PID algorithm design methods, namely; Ziegler -Nichols tuning rules [1][7][8], Chein-Hrones-Reswick [9] and Cohen and Coon [10], in literature, there exit and can be found various conventional (expressions) formula-based PID algorithm design methods suggested to meet time-domain specifications and/or disturbance rejection [11][12][13][14][15][16][17][18], (you may see also [5] and references therein), every method has its strength advantages, limitations and disadvantages. Most existing expressions-based PID algorithm design methods are built consisting of repeated steps, namely; insight into plants dynamics, selecting algorithm gains, process simulation, testing, analysis and modification. In [11] authors suggest an optimal new method for tuning PID controllers for FOPDT systems; the method was suggested based on applying two techniques dimensional analysis and numerical optimization. In [19] authors with the help of simulation aspects and MATLAB built in function suggested an improved PID tuning method based on well-known Ziegler-Nichols tuning method. In [21], author suggest, based on relating parameters of both controller's and system's to be controlled, a new and simple efficient model-based PID modes design method.

The main goal of this work is to derive and suggest simple and easy to apply expressions to design a PID control algorithm, P-, PI, PD, and PID modes, indented for controlling the performance of first order systems and systems

that can be approximated as such. To achieve a desired output value with acceptable stability, response without or with minimum possible overshoot, oscillation and error. This work is organized into the following sections; in section 2: design and testing methodologies are presented, in section 3: are presented overall System and subsystems representation and modeling. In section 4, 4 expressions for designing PI (proportional-derivative)- and PID-algorithms are introduced. Section 5 includes the experimental testing analysis and discussion of results. In section 6, experimental setup for system identification is presented; finally, conclusions are drawn.

2. Methodology for PID algorithm modes design and testing

In current work, new expressions based PID control algorithms design method are to be presented for controlling the dynamics of FOSTD systems, and systems that can be approximated as such. The method is limited to design two PID modes namely, PI, and PID. As represented by Eq.(1). The suggested expression based design method is built around relating control algorithm parameters namely; gains; K_P , K_I , K_D , T_I , T_D , to the parameters of FOSTD system to be controlled, namely; time delay L , system dc gain K_{DC} time constant T , in addition, desired reference output value R .

Function given by Eq.(1) is manipulated and reduced to the smallest number of essential needed system variables to result in simple, linear and easy to use expressions, for estimating control algorithm's gains that will get the plant under control and result in overall stable system responding with acceptable response fastness, minimum possible overshoot, oscillation and error. In addition, the following methods were applied to derive these expressions; mathematical representation, Dimensional analysis, software simulation, testing and analysis of the resulted step response, finally trial and error.

To test applicability and correctness of the derived expressions for PI and PID algorithms design, MATLAB/Simulink software is used to build overall system software simulation model, as well as, analyze and evaluate design using suggested expressions for various FOSTD types and forms. The developed software Simulink model is shown in Figure 1(a), it was built assuming Microcontroller based control unit is used. The used PID algorithm Simulink sub model, with its various forms and filter is shown in Figure 1(b). To help assessing both the design method and resulted overall system response, the software Simulink model was built such that it returns and displays maximum needed data needed for assessment, in both numerical and graphical forms. The next data are returned; response measures, namely; T_R , T_s , E_{ss} , $PO\%$, and performance indices given by Eq.(2), namely IAE and ISE. to refine the model, and to simulate as possible real life values and situation, signal processing, limitation and saturation Simulink blocks were utilized, these were used to limit the generated by microcontroller output control signal value within $[\pm 5]VDC$ range, also to limit the generated by sensor output signal to be within $[0-5VDC]$ range. Moreover, to amplify $\pm 5VDC$ control signal value, to the required, by actuator power level, an amplifier/drive circuit model was used.

To test and evaluate the applicability and efficiency of the derived expressions, various FOSTD systems' types and forms, and systems that can be approximated as such were used in the simulation, in particular, systems with small, medium and large time constants, DC gains, and time delay, unstable systems, systems with variable delay, most of these systems are given by Eqs. (3) (4). In Eq.(4) are given both higher order system followed by its approximation as first order system. Furthermore, to assess the efficiency of suggested design expressions, the resulted overall system responses were compared with resulted responses when the next two design methods were applied; the worldwide known Ziegler Nichols PID algorithm design method and Simulink auto-tuned PID block.

In testing the design expressions, the control problem is to achieve overall system smooth response, to reach and maintain desired output $R(s)$ with acceptable response fastness, without or with minimum observable overshoot, oscillation and steady state error.

$$K_x = f_x(T, L, K_{DC}, R) \tag{1}$$

$$\int_0^\infty e^2(t) dt \tag{2}$$

$$\int_0^\infty |e(s)| dt$$

$$\begin{aligned}
 G_{sys_1}(s) &= \frac{3}{5s+1} e^{-0.9s} \\
 G_{sys_2}(s) &= \frac{0.1}{2s+100} e^{-0.5s} \\
 G_{sys_3}(s) &= \frac{0.005}{s+10} e^{-0.3s} \\
 G_{sys_4}(s) &= \frac{250}{100s+1} e^{-0.2s}
 \end{aligned} \tag{3}$$

$$\begin{aligned}
 G_{sys_5}(s) &= \frac{50}{s^2+15s+50} e^{-0.5s} \\
 G_{app}(s) &= \frac{1}{0.2s+1} e^{-0.5s} \\
 G_{sys_5}(s) &= \frac{0.05}{2s^2+9s+1} e^{-0.3s} \\
 G_{app}(s) &= \frac{0.05}{8.7719s+1} e^{-0.3s} \\
 G_{sys_6}(s) &= \frac{10000}{s^4+126s^3+2725s^2+12600s+100000} e^{-0.5s} \\
 G_{app}(s) &= \frac{1}{s+1} e^{-0.5s}
 \end{aligned} \tag{4}$$

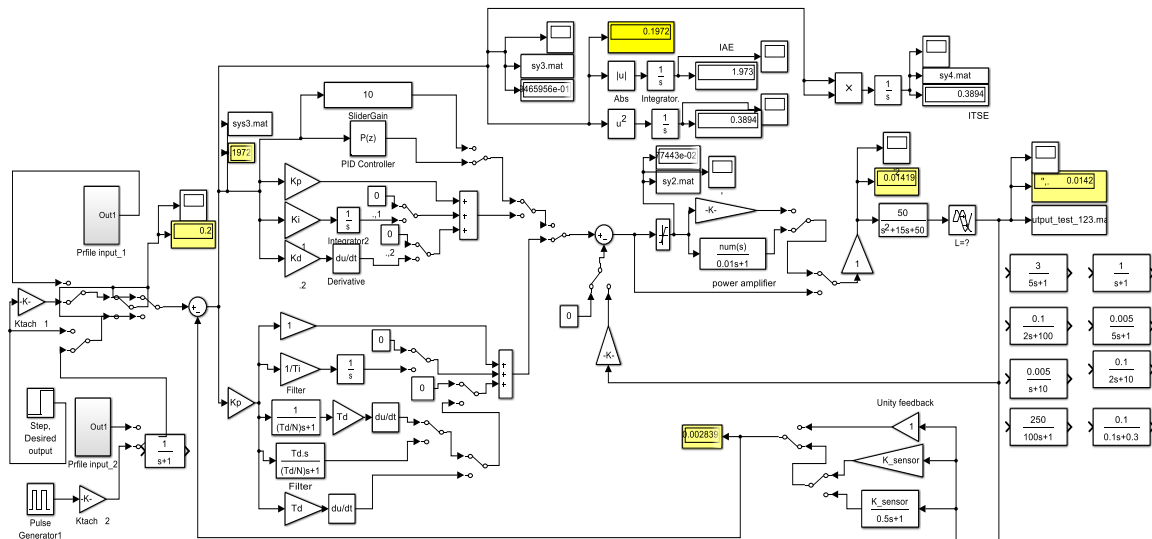
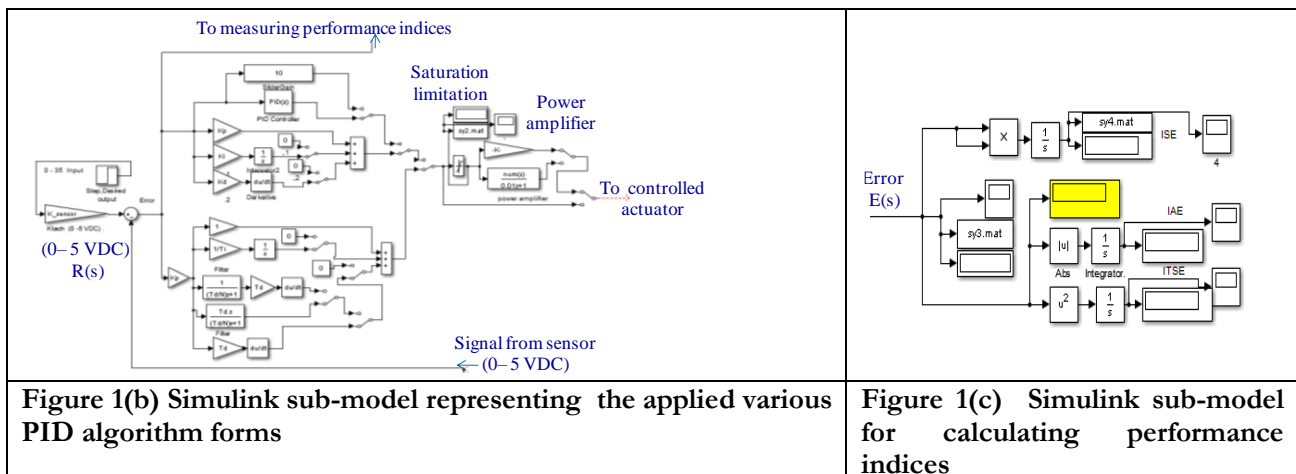

Figure 1(a) overall system software Simulink model to test and evaluate expressions



3. System representation and modeling

3.1 First order systems with time delay FOPTD

There exist various ways to model processes with time delay, such systems can be classified into various models, examples include; integral with delay model IPD, stable first order plus time delay FOPTD, model and Second order with delay time SOPDT, the present work is developed for application with first order system plus time delay FOPTD.

As noted, Many industrial plants are represented mathematically by FOPTD process [21][22]. FOPTD models consist of two parts, namely; first order system model and the delay-time. Its general transfer function form is given by Eq.(5) and is represented using block diagrams as shown in Figure 2(a-b). The response of FOPTD is the s-shape response curve shown in Figure 3, also called reaction curve, in this s-shape response curve, three system parameters can be identified, namely; time constant T , time delay L , and steady state dc gain level K_{DC} .

$$G(s) = \frac{K_{DC}}{T_s} e^{-Ls}$$

$$T(s) = \frac{\text{Output}}{\text{Input}} = \frac{G(s)}{1+G(s)H(s)} \quad (5)$$

$$T(s) = \frac{K_{DC}}{Ts+1} e^{-Ls}$$

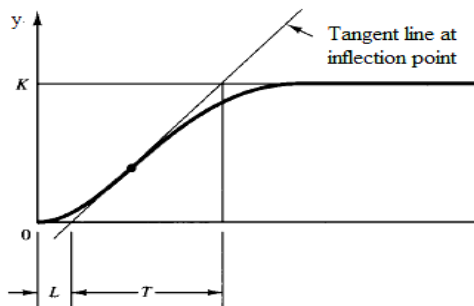
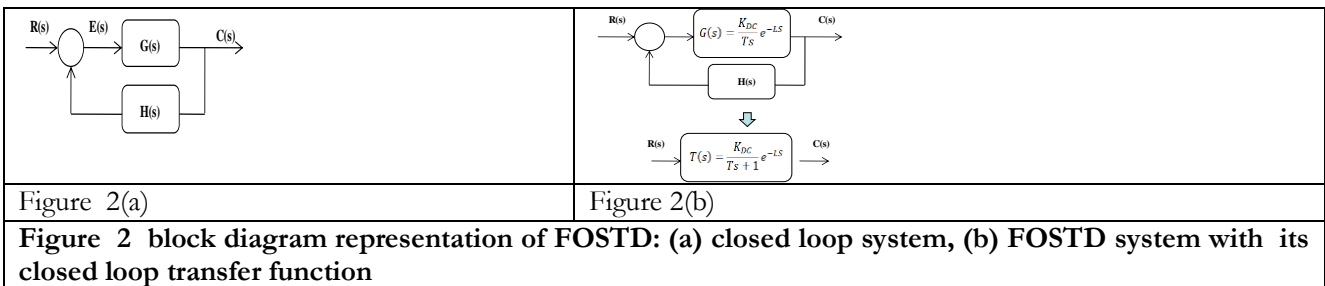

Figure 3: FOPDT S-shaped response curve with terminology.

3.2 Mathematical modeling of PID control algorithm forms

The PID control algorithm has seven modes, namely; P-, PD-, PI- and PID algorithms, in addition, the approximation forms named lead, lag and lead-lag compensators. This work limited to PI- and PID algorithms design

The Proportional P- Control algorithm, generates instant output control action signal $u(t)$, that is proportional to the error value $e(t)$, as given by Eq.(6). Meanwhile, the Proportional plus integral control algorithm PI, as shown by Eq.(7), generates output control signal that is equal to the sum of two signals, namely; error and the integral of error. Here in addition to P- terms action that improves response up to a limit, the integral I-term reduces the error to minimum possible, in the longer term [23]. In Eq.(7), $Z_{PD} = K_i / K_p$, is the algorithm zero. T_i is the algorithm

integral time constant. Finally, the Proportional plus Integral plus Derivative control algorithm PID, generates output control signal that is equal to the sum of error, the integral of error and the derivative of the error, as given by Eq.(8). Beside the actions of P- and I-terms, the derivative D-term generates additional control action, that results in increasing system both stability and response speed. The D-term works when the error changes consistently.

PID algorithm can be represented mathematically in different forms, transfer function, in terms of integral and derivative time constants as given by Eq.(9) where: $T_D = K_D / K_P$: derivative time constant and $T_I = K_P / K_I$: integral time constant. Moreover, since, Eq.(9) cannot physically be implemented, because it is not causal, it is written in modified realizable form by adding a lag to its derivative part, as given by Eq.(10), or by Eq.(11), where: T_D/N is the added lag time constant.

$$u(t) = K_p * e(t) \rightarrow U(s) = K_p * E(s)$$

$$G(s) = \frac{U(s)}{E(s)} = K_p \tag{6}$$

$$u(t) = K_p * e(t) + K_I * \int de(t)$$

$$U(s) = K_p * E(s) + K_I E(s) \frac{1}{s}$$

$$G_{PI}(s) = K_p + K_I \frac{1}{s} = \frac{K_I(s + \frac{K_I}{K_P})}{s} = \frac{K_P(s + Z_{PI})}{s} \tag{7}$$

$$G_{PI}(s) = K_p \left(1 + \frac{1}{T_I s}\right)$$

$$u(t) = K_p * e(t) + K_D \frac{de(t)}{dt} + K_I * \int de(t)$$

$$U(s) = K_p * E(s) + K_I E(s) \frac{1}{s} + K_D s E(s) \tag{8}$$

$$G_{PID}(s) = \frac{K_D(s^2 + \frac{K_P}{K_D}s + \frac{K_I}{K_D})}{s} = \frac{K_D(s + Z_{PI})(s + Z_{PD})}{s}$$

$$G_{PID}(s) = K_p \left(1 + \frac{1}{T_I s} + T_D s\right) \tag{9}$$

$$G_{PID}(s) = K_p \frac{T_I T_D s^2 + T_I s + 1}{T_I s}$$

$$G_{PID}(s) = K_p \left(1 + \frac{1}{T_I s} + \frac{T_D s}{1 + \frac{T_D s}{N}}\right) \tag{10}$$

$$G_{PID}(s) = K_p + K_D s + K_I \frac{1}{s}$$

$$G_{PID}(s) = K_p + \frac{K_D s}{1 + s T_I} + K_I \frac{1}{s} \tag{11}$$

$$G_{PID}(s) = \frac{(K_p T_I + K_D) s^2 + (K_p + K_D T_I) s + K_I}{s(T_I s + 1)}$$

The two equations, Eq. (10) and Eq. (11), show that PID algorithm model is a II order system, that can be represented in terms of II order system parameters, namely undamped natural frequency and damping ratio as given in Eq. (12) and Eq. (13) where:

$$2\omega \varepsilon = K_p / K_D \quad \text{and} \quad \omega_n^2 = K_I / K_D$$

$$G_{PID}(s) = \frac{K_D(s^2 + \frac{K_P}{K_D}s + \frac{K_I}{K_D})}{s} \tag{12}$$

$$G_{PID}(s) = \frac{K_D(s^2 + 2\zeta \omega_n s + \omega_n^2)}{s}$$

$$G(s) = K_P + K_D s + K_I \frac{1}{s}$$

$$G(s) = \frac{(K_P T_I + K_D) s^2 + (K_P + K_D T_I) s + K_I}{s(T_I s + 1)} \quad (13)$$

$$G(s) = \frac{K_D (s^2 + 2\epsilon\omega_n + \omega_n^2)}{s}$$

4. Expressions for designing PI- and PID- algorithms

Linear, simple and easy to use expressions for designing PI- and PID algorithms first order systems with time delay FOSTD are derived and presented in Table 1. Referring to these expressions, time constant T, time delay L, dc gain K_{DC} and the desired reference output value R, are needed to design any of the two algorithms and assigning its parameters namely, K_P, K_I, K_D, T_I, T_D in these expressions only one tuning parameter named A, is introduced. This parameter is applied, in case it is required to further improve the resulted response.

Table 1: suggested expression for PID- and PI- algorithms design

Algorithm/ when to apply		K _P	K _D	K _I
PID	all system	$\frac{6 * L}{K_{DC} * T}$	0.14*K _P	0.18*K _P
	Systems with mall T and /or big K _{DC}	$A * \frac{6 * L}{K_{DC} * T}$	0.14*K _P	0.18*K _P
PI	all system	$A * \frac{6 * L}{K_{DC} * T}$	0	0.18*K _P
	Systems with mall T and /or big K _{DC}	$\frac{0.9 * T}{L}$	0	$\frac{L}{0.3}$

5. Testing, analysis, evaluation and discussion

To Test the correctness and applicability of the presented expressions, to analyze and evaluated the results, MATLAB/Simulink environment was used to developed the software simulation model shown in Figure 1. In this model, are applied and used various types and forms of FOSTD system and systems that can be approximated as such. The software model is developed consisting of the next sub-models; input signals, different mathematical forms of PID algorithm, PID Simulink auto-tuned block, drive circuit (amplifier), sensor feedback, finally, data displaying and analysis sub-models.

The experimental set up is built such that, the derived expression for designing PID-, PI- algorithms are applied to control the behavior of each of FOSTD systems given by Eqs. (3),(4). To further evaluate expressions, the same systems were controlled applying PID auto-tuned Simulink block applied to select optimal gains values, and finally Ziegler-Nichols expressions are applied. for further analysis and evaluation, the resulted numerical and graphical data are recorded namely, resulted response curves, estimated gains; K_P, K_I, K_D T_I, T_D, response measures namely, T_R, T_S, E_{SS} ,PO% , finally IAE and ISE performance indices.

5.1 Testing expressions for PID algorithm design and discussion

The suggested expressions for designing PID algorithm followed by PID auto-tuned Simulink block were test by applying it to control the behavior of all system given by Eqs. (3) and (4). In both testing cases, and for every system, the numerical data results are recorded and listed in Table 2. The resulted graphical response curves are shown in Figure 4 (a-e). Results were screened, analyzed, and compared when the same system were controlled by PID auto-tuned block. This process shows that, in all cases, for all systems, the suggested expressions gave better results in terms of response speed and cost. The expressions results in smooth and fast system response, without any overshoot and with less error, in addition, in comparison with results obtained applying Auto-tuned block; the response applying expressions are with lower values of performance indices ISE and IAE.

It is important to mention that, in most of testing cases, it was very difficult to design PID algorithm utilizing auto-tuned block, many auto-tuning runs followed by manual softening were done to achieve the resulted and shown responses. For six systems of the seven tested, the resulted derivative gain K_D , were with negative values.

Table 2: testing result when systems controlled applying suggested expressions and Simulink PID auto-tuned Block

Sys	Method	T	L	K _D	R(s)	A	K _P	K _I	K _D	T _I	T _D	N	P O %	T _R	T _s	5 T	E _s	IS E	IA E
Sys (1)	Suggested expressions	5	0.9	3	3	1	9	1.62	1.26	5.556	0.14	1	-	15.5	-	36.5	0	19.2	34.9
	MATLAB PID block					-	0.3287	0.13019	-2.818	5.56	0.14	0.0893	-	20.5	-	48	0	38.3	82.27
Sys (2)	Suggested expressions	0.02	0.5	0.001	0.001	1	15000	2700	2.100	5.556	0.14	1	-	0.55	-	0.6	0	82e-4	7.3e-7
	MATLAB PID block					-	2322.1	1290.93	1615.	1.798	0.695	0.2885	-	10	-	30	0	34e-4	1.76e-6
Sys (3)	Suggested expressions	0.1	0.3	0.005	0.005	1	3600	648	-504	5.556	0.14	1	-	0.7	-	1	0	0.01395	6.45e-5
	MATLAB PID block					-	61314.76	4756.60	-12021.21	12.89	-1.96	0.31619	-	0.7	-	1	0	0.998	0.1998
Sys (4)	Suggested expressions	5	0.2	250	250	1	0.016	0.0029	0.002	5.556	0.14	1	-	222	-	643	0	2515	317300
	MATLAB PID block					-	0.0424	0.0058	-0.6359	73	-14.99	0.0641	-	238	-	665	0	2599	337700
Sys (5)	Suggested expressions	5	0.3	1	1	1	0.36	0.0648	0.054	5.556	0.14	1	-	0.85	-	2	0	1246	310600
	MATLAB PID block					-	7.2029	0.03021	-15.09	238.4	-2.09	0.3845	-	0.9	-	24	0	1246	310600
Sys (6)	Suggested expressions	8.77	0.5	0.005	0.005	1	180	32.4	25.2	5.556	0.14	1	-	0.9	-	2.1	0	0.22	0.03259
	MATLAB PID block					-	16.141	9.5665	-6.533	1.68	-0.404	0.3558	-	3.45	-	17.5	0	0.43	0.04969
Sys	Suggested	1	0	1	1	1	5.4	0.9	0.7	5.5	0.1	1	-	62.	-	1	0.0	5.1	0.46

(7)	ed expressi ons	5					72	56	55	4			5		5	1	15	89
	MATL AB PID block						-	17.4	2.8	-			6.1		-	0.	-	21
							30	49	37	16	2.1	16	95		0		55	88

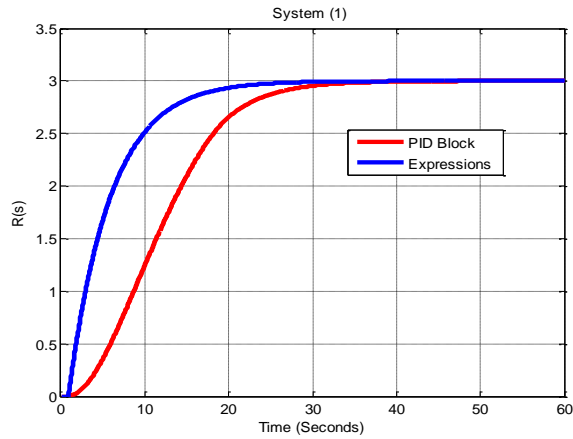

Figure 4(a): Testing system (1) applying expressions and PID auto tuned Block

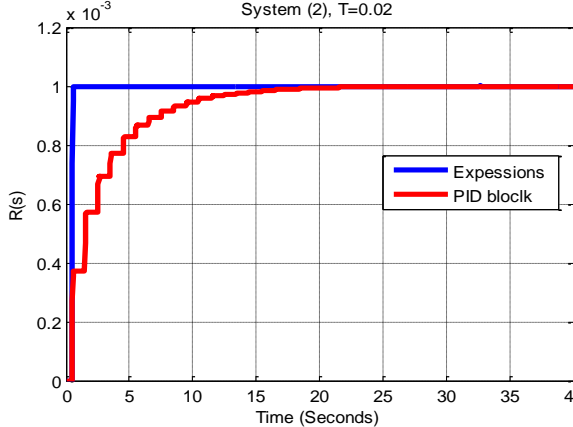

Figure 4(b) Testing system (2) applying expressions and PID auto tuned block.

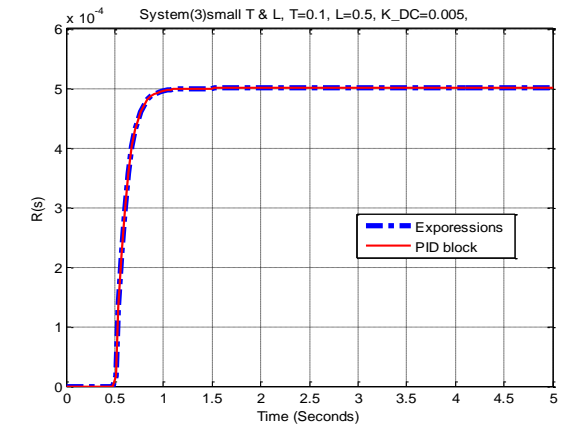

Figure 4(c) Testing system (3) applying expressions and PID auto tuned block.

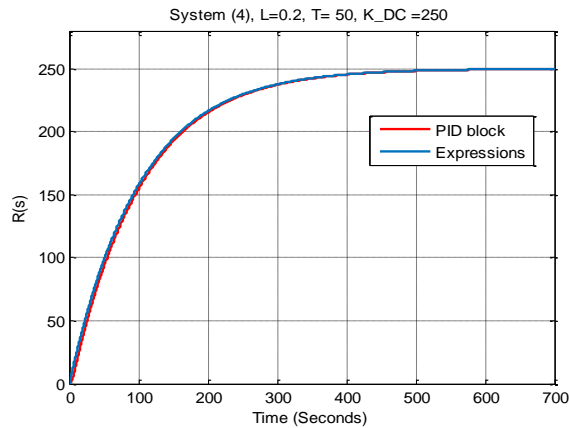

Figure 4(d): Testing system (4) applying expressions and PID auto tuned block.

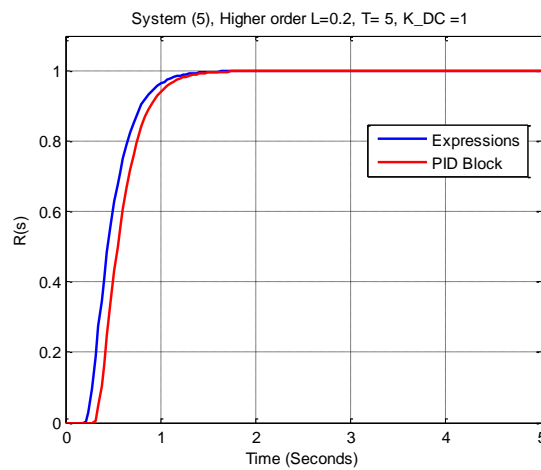

Figure 4(e) Testing second order system (5) approximated as first order applying expressions and PID auto tuned block.

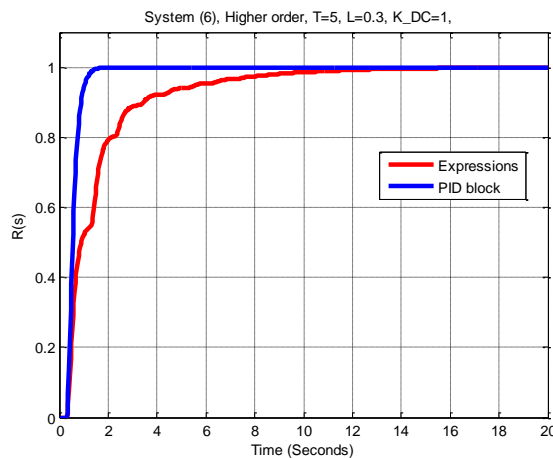

Figure 4(f) Testing second order system (6) approximated as first order applying expressions and PID auto tuned block.

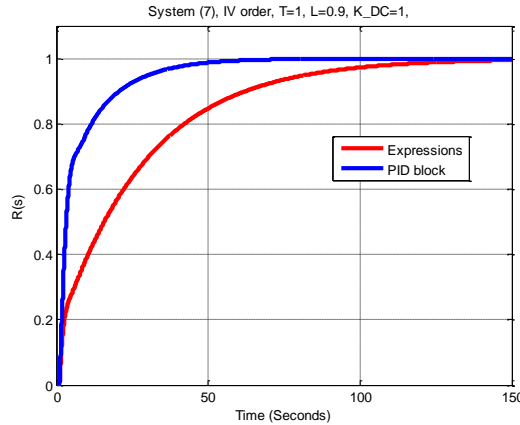

Figure 4(g) Testing IV order system (7) approximated as first order applying expressions and PID auto tuned block.

5.2 comparing suggested expressions with Ziegler-Nichols expressions

New four specially selected systems given by Eq.(14), for further expressions testing and evaluation, the system are selected with small, medium and big values of time constant , time delays and DC gain. To design PID algorithms for controlling each of these systems, three design methods were applied and compared; the suggested expressions, Ziegler-Nichols expressions and MATLAB PID auto tuned block. The resulted numerical data are listed in Table 3. The resulted graphical results are shown in Figure 5(a-d)

The numerical and graphical results, for every system, were screened, analyzed and compared. Analysis show that, in most cases, the expressions results in better response than applying Ziegler Nichols and PID auto-tuned block, all systems responds without any observed overshoot or oscillation and with lower performance indices values.

The tuning parameter A, was very helpful in improving resulted response, it has the effects of speeding up response, reduce overshoot, oscillation and error.

In most testing cases, it was difficult to design PID algorithm, many auto-tuning runs followed by manual softening were done to achieve the resulted response, In some testing cases ,e.g. system (a), negative gain values were obtained,

$$\begin{aligned}
 G_{sys_a}(s) &= \frac{1}{s+1} e^{-0.3s} \\
 G_{sys_b}(s) &= \frac{0.005}{5s+1} e^{-0.9s} \\
 G_{sys_c}(s) &= \frac{0.1}{2s+10} e^{-0.2s} \\
 G_{sys_d}(s) &= \frac{0.5}{8.7719s+10} e^{-0.5s}
 \end{aligned}
 \tag{14}$$

Table 3: Comparing the resulted responses applying suggested expressions with Ziegler-Nichols.

Sys	Method	T	L	K _{DC}	R(s)	A	K _P	K _I	K _D	T _I	T _D	N	P O %	T _R	T _s	5 T	E _s	IS E	IA E
Sys (a)	Suggested expressions	1	0 , 3	1	1	8.1	14.5 8	2.6 24 4	2.0 41 2	5.5 55 6	0.1 4	1	-	2.6	-	2 4	0	1.8 99	1.2 27
	Ziegler- Nichols					-	4	6.6 7	0.6	0.5 99 7	0.1 5	1	1	2.8	-	8. 5	0	1.8 1	1.2 27

	MATLAB PID block					-	47.56.60	-12.02.12.15	12.89	-1.96	0.31619	-	2.5	-	8.5	0	1.81	1.227	
Sys (b)	Suggested expressions	5	0.9	0.005	1	1	21.6	38.88	30.24	5.556	0.1400	1	-	12.5	-	2.5	0	29.88	28.76
	Ziegler-Nichols						6.67	3.7	3	1.8027	0.4498	1.1115	-	12.5	-	2.5	0	24.91	26.81
	MATLAB PID block						-	12.834	26.1532	21.2662	4.90	0.165	1.1115	-	12.5	-	2.5	0	29.88
Sys (c)	Suggested expressions					1	60.0	10.8	84	5.556	0.14	1	-	0.667	-	1.6	0	4.959	4.919
	Ziegler-Nichols						1.2	3	0.12	0.4	0.1	1	-	1.51	-	2.4	0	4.964	4.928
	MATLAB PID block						-	12.833	26.1532	21.2663	4.9	0.165	1.1114	-	1.56	-	2.4	0	4.964

Sys (6)	Suggested expressions	8.7719	5.5	0.05	0.05	1	75.1794	13.5323	10.5251	5.556	0.14	1	-	25.55	-	6.0	0.001	76.74	73.63	
	Ziegler-Nichols						-	1.9154	0.1741	5.2674	11	2.75	1	-	33.3	-	7.4	0.001	76.97	74.07
	MATLAB PID block							107.920	9.719	79.8121	11.10	1.97	1.7083	-	25.5	-	6.75	0.001	76.74	73.63

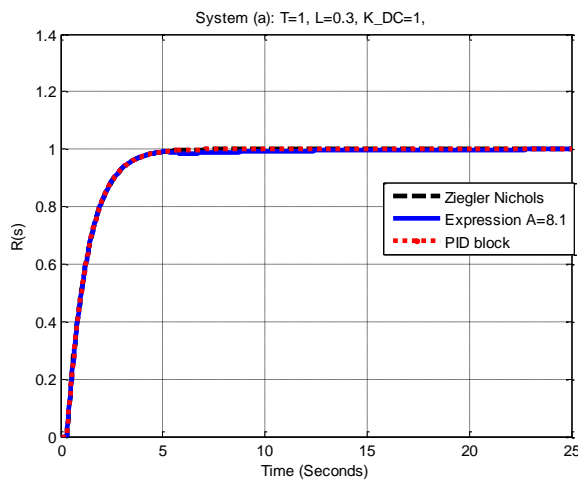

Figure 5(a): Testing system (a) applying: expressions, Ziegler Nichols, PID auto-tuned block.

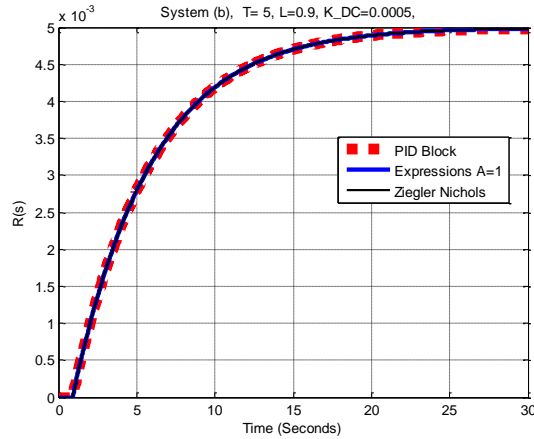

Figure 5(b): Testing system (b) applying expressions, Ziegler Nichols, PID auto-tuned block.

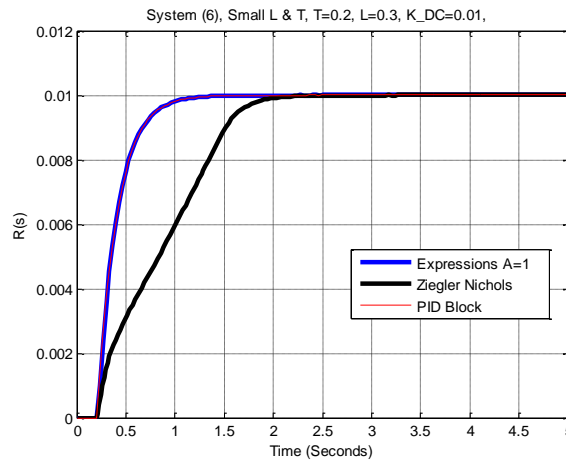

Figure 5(c): Testing system (c) applying expressions, Ziegler Nichols, PID auto-tuned block.

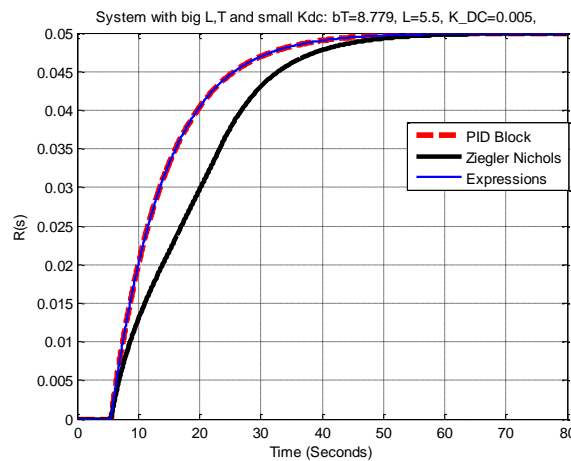

Figure 5(d) Testing system (d) applying expressions, Ziegler Nichols, PID auto-tuned block.

5.3 Testing PI algorithm design and discussion

The suggested expressions for designing PI algorithm followed by PID auto-tuned Simulink block were test by applying it to control the behavior of all system given by Eqs. (3), (4). The testing results in terms of response measures and performance indices were recorded and listed in Table 4. Meanwhile the graphical results in terms of response curves are shown in Figure 6(a-g). Studying and analyzing these results show that, in most cases, suggested

expression result in better control over system response with less error value and lower performance indices values. In some cases to further, improve the resulted response, tuning parameter B, shown efficient effect in speeding up response, reducing overshoot and error

For system (2), that is with small T, L and KDC gain, Ziegler-Nichols method results in very slow response that is now observable in Figure 6(b).

Table 4: testing result when systems controlled applying suggested expressions and Simulink PI auto-tuned Block

Sys	Method	T	L	K _D c	R(s))	B	K _P	K _I	T _I	P O %	T _R	T _S	5T	E _{SS}	ISE	IAE	
Sys (1)	Suggested expressions	5	0.9	3	1	1	0.9	0.162	5.5556	-	21.8	-	63	0.001	10.27	5.697	
	Ziegler Nichols					-	5	1.6667	3	0.51	2.7	20	38	0	4.253	2.498	
	MATLAB PI block					-	1.5459	0.15477	9.9884	-	26	-	87	0.004	10.21	4.622	
Sys (2) Small T,L, K _{DC}	Suggested expressions	0.02	0.5	0.001	0.001	25	1500	270	5.5556	-	50	-	140	0	0.01826	7.537e-6	
	Ziegler Nichols					-	0.0360	0.0216	1.6667	-	-	-	-	-	-	-	-
	MATLAB PI block					-	297.896	595.792	0.5	-	16	-	53	0.001	0.00796	0.00045	
Sys (3)Small T,L, KDC	Suggested expressions	0.1	0.3	0.005	0.005	25	9000	1620	5.5556	-	20	-	160	0	0.00308	4.833e-7	
						6	2160	388.8	5.5556	-	65	-	160	0.0001	0.01248	2.74e-6	
	Ziegler Nichols					-	0.3	0.3	1	-	-	-	-	-	-	-	
	MATLAB PI block					-	297.89629	595.792	0.5	-	35	-	91	0	0.0081	2.161e-6	
Sys (4)	Suggested expressions	100	0.2	250	250	1	0.0480	0.0086	5.5556	-	250	-	700	0	2515e4	3169e6	
	Ziegler Nichols					-	450	675	0.6667	-	250	-	700	0	2515e4	3169e6	
	MATLAB PI block					-	0.0871699	0.000875	99.6227	-	250	-	700	0	2515e4	3169e6	
Sys (5)	Suggested expressions	0.2	0.3	1	1	25	2.16	0.3888	5.5556	-	-	-	101	0.001	12.82	4.916	
	Ziegler Nichols					-	0.6	0.6	1	-	18.5	-	60	0	8.333	4.243	
	MATLAB					-	2.033	1.4	1.3	-	5.5	-	28	0	2.9	1.66	

	PID block						5858	6902	843						6	7			
Sys (6)	Suggested expressions	8.7719	0.5	0.05	0.05	25	1.3158e+04	2.3684e+03	5.5556	-	21	-	65	0	0.5005	0.01402			
	Ziegler Nichols					-	15.7894	9.4737	1.6667	-	28	-	70	0	0.7174	0.02348			
	MATLAB PI block					-	358.516	31.3033	11.453	-	20	-	70	0	0.5005	0.01402			
Sys (7)	Suggested expressions	1	0.5	1	1		15	2.7	5.5556	-	3.1	-	11	0	2.27	1.673			
	Ziegler Nichols																		
	MATLAB PI block																		

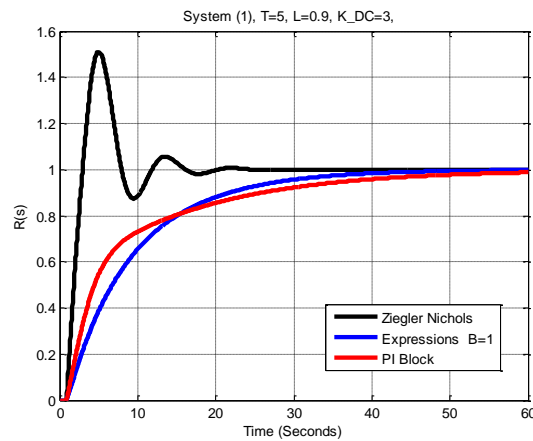

Figure 6(a) Testing system (1) applying: expressions, Ziegler Nichols and PID auto-tuned block.

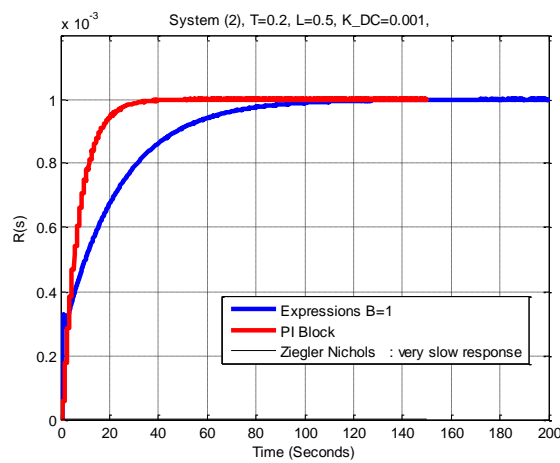

Figure 6(b) Testing system (2) applying only expressions, and PID auto-tuned block.

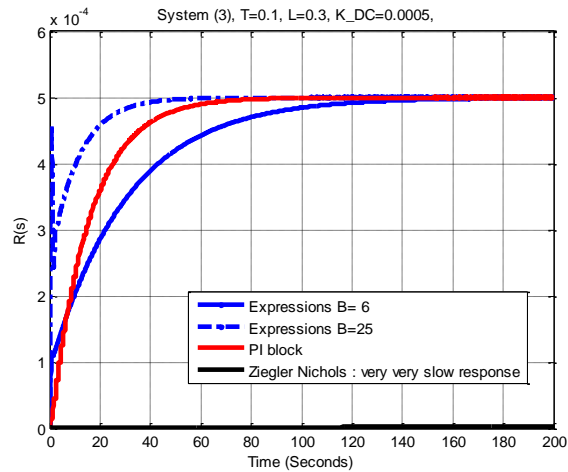

Figure 6(c): Testing system (3) applying: expressions, Ziegler Nichols and PID auto-tuned block.

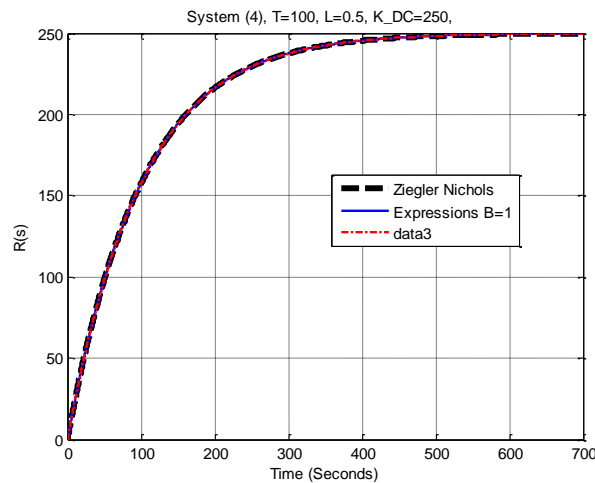

Figure 6(d): Testing system (4) applying: expressions, Ziegler Nichols and PID auto-tuned block.

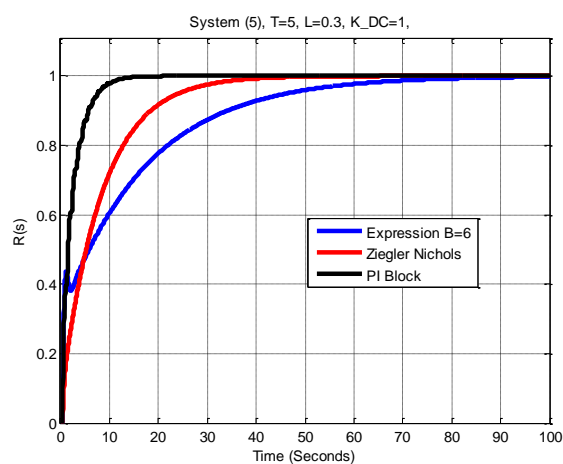

Figure 6(e): Testing system (5) applying: expressions, Ziegler Nichols and PID auto-tuned block.

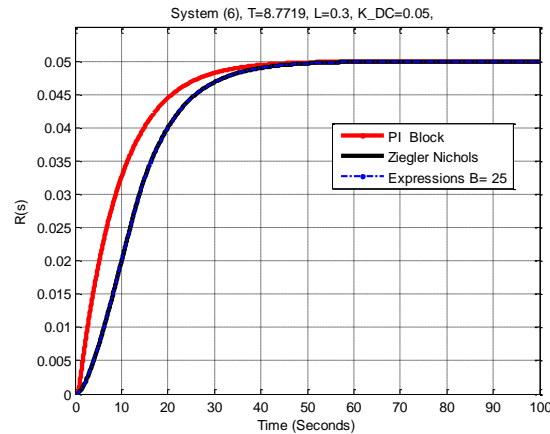

Figure 6(f): Testing system (6) applying: expressions, Ziegler Nichols and PID auto-tuned block.

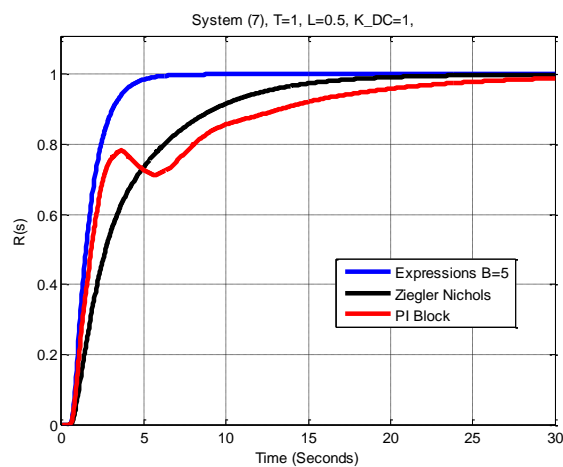

Figure 6(g): Testing system (7) applying: expressions, Ziegler Nichols and PID auto-tuned block.

5.4 Analysis, Evaluation and Discussion of testing results

Studying numerical and graphical testing results reveals that the suggested expressions for designing PID- and PI- algorithm are applicable and efficient in controlling the behavior of all selected and tested forms of first order system with time delay and system that are approximated as such. Applying these expressions, results a much better response results than when Ziegler Nichols and/or auto-tuned PID Simulink block were applied. Analysis also shows that, all select systems respond with acceptable fast response, without overshoot or oscillation, in addition, with lower error, ISE, and IAE indices values

To further improve the resulted response, the tuning parameters A and B were very effective to speed up resulted response, reduce overshoot, rise time and settling time as well as error.

5.5 Testing expressions for special cases and discussion

As noted, The PID, control algorithm is considered most commonly applied and dominant algorithm for controlling the dynamics of industrial applications. However, for some system types and cases, the algorithm will not perform well as expected. To test the suggested expressions' applicability, efficiency and robustness to design algorithm that is capable of controlling systems with special dynamics, namely, variable time delay process, higher order system approximated as FOSTD, systems with very small and/ or very big time constant, time delay and dc gain values. Such systems are represented in transfer function form as given by Eqs.(15) by (18). Each of these systems' parameters are used to design PID algorithm for corresponding system, Recorded numerical algorithm design testing results are listed in table 5. Meanwhile graphical result are shown in Figures 7(a-d). These transfer functions are explained as follows: Temperature control in heater tank system is represented by Transfer function

given by Eq.(15). A process with variable time delay is represented as by Eq.(16), this is a quality control of continuous steel casting, This transfer function of this system, is developed capturing the delay and losses considering components of which the quality system consists; namely; the hydraulic actuator, the dynamics of stopper, sensor for the stopper position [24]. Unstable first order system is given by Eq.(17). Water volume tank heating system is given by Eq.(18)

Studying the graphical and numerical testing results show the following:

(a) For Temperature control in heater tank system; the system responds with acceptable stability, speed of response and error. The system’s response measures and performance indices ISE, IAE are better than when each of two methods, Ziegler-Nichols and PID Auto-tuned block, were applied. It is important to mention that, it was difficult to design PID algorithm using Simulink auto-tuned block. Moreover, applying Ziegler Nichols expressions to control this system, resulted in inversed response curve as shown in Figure 7(a) . To result in normal response curve, not inversed going down to negative side, any of the next two observations can be suggested : (1)the time delay L, is given a negative sign and then proceed with calculating gains or (b)given a negative sign to all calculated gains and apply to control the system (see next system).

(b) For controlling the behavior of a process with variable time delay; the expression were very efficient in control the system, resulting in acceptable stability level, speed of response and zero error value as well as, with better response than when both Ziegler Nichols and PID Auto-tuned block are applied. the same observation can be made for applying Ziegler Nichols expressions, were all calculated by expressions gains are given negative sign and applied to control the process to result, normal not inversed response as shown Figure 7(b)

(c) to control the behavior of unstable system; its parameters L, T, K_{DC}, are applied to design the algorithm using its absolute (positive) values. to further improve resulted response to result in higher stability level, parameter A, is tuning. Both PID auto-tuned block and Ziegler Nichols expression show a shortage in controlling such systems, in terms of very big overshoot and undamped oscillation.

(d) For controlling the behavior of water volume tank heating system; the applied three methods were almost identical in results and achieving similar system acceptable response

$$G(s) = \frac{-764.5}{14s+1} e^{-4s} \tag{15}$$

$$G(s) = \frac{-8}{10s+1} e^{-30s} \tag{16}$$

$$G(s) = \frac{1}{0.5s-0.2} e^{-0.2s} \tag{17}$$

$$G(s) = \frac{5}{6s+1} e^{-4.2s} \tag{18}$$

Table 5: Testing and comparing result when special form systems and cases are controlled applying suggested expressions, Ziegler Nichols expression, and Simulink PID auto-tuned Block

Sys	Metho d	T	L	K _D c	R(s)	A	K _P	K _I	K _D	T _I	T _D	N	P O %	T _R	T _s	5 T	E _s	IS E	IA E
Heate r tank syste m	Suggest ed expressi ons	1 4	4	- 7 6 4. 5	80 0	1	- 0.0 02 2	- 4.0 36 3e - 04	- 3.1 39 3e -4	5.5 55 6	0.1 4	1	-	36. 37	-	1 0 0	0	72 08 0	176 2e +5
	Ziegler Nichols					-	4.2	0.5 25	8.4	8	2	1	-	36. 4		1 1 8	0	27 28 e+ 6	214 2e +8

	MATLAB PID block					-	-	-	-	16.67	0.559	0.8344054	-	36.37	-	10	0	72080	1762e+5
process with variable time delay	Suggested expressions	10	30	-0.8	1	1	-	-	-	5.556	0.14	1	-	53	-	10	0	200	875.4
	Ziegler Nichols					-	-	-6	-	60	15	1		77.6	-	123	0.001	1245	10900
	MATLAB PID block					-	-	-	0.579771	24.94	-12.98	0.0200271	-	75	-	1222	0	264.2	108
Unstable system	Suggested expressions	-2.5	0.2	-5	1	1	0.0960	0.01734	0.0134	5.5566	0.14	1	Unstable response						
	Ziegler Nichols					9	0.8640	0.1555	0.1210	5.5566	0.14	1	33%	7.5	16	20	0	11.23	18.85
	MATLAB PID block					-	15	37.5	1.5	0.4	0.1	1	120%	0.6	-	-	±0.35	31.98	87.99
	Ziegler Nichols					-	0.834	0.21328	0.12378	3.91	0.148	1.2860	150%	0.65	4.2	80	0	11.66	50.56
tank heating system	Suggested expressions	6	4.2	5	1	1	0.84	0.1512	0.1176	5.5566	0.14	1	-	18		43	0.003	306.2	6489
	Ziegler Nichols					-	1.7143	0.2041	3.6	8.4	2.1	1	-	18	-	48	0.003	306.2	6489
	MATLAB PID block						0.834	0.21328	0.12378	3.911	0.148	1.2860	-	19.1		44		306.2	6489

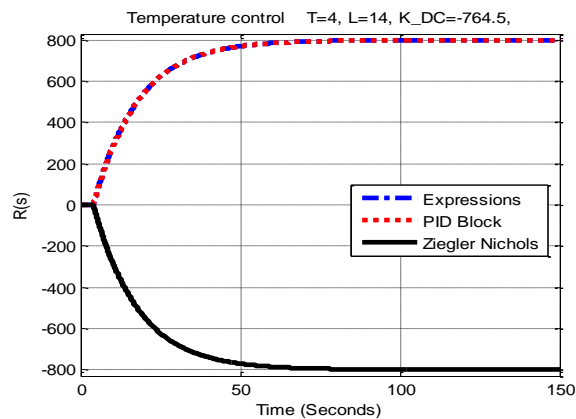

Figure 7(a): Testing control over Temperature control in heater tank system.

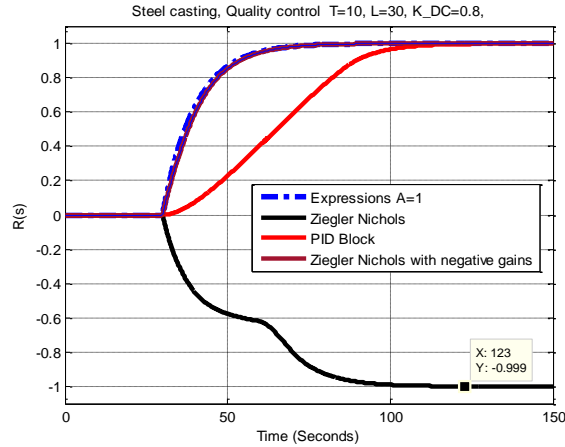

Figure 7(b): Testing control over a process with variable time delay.

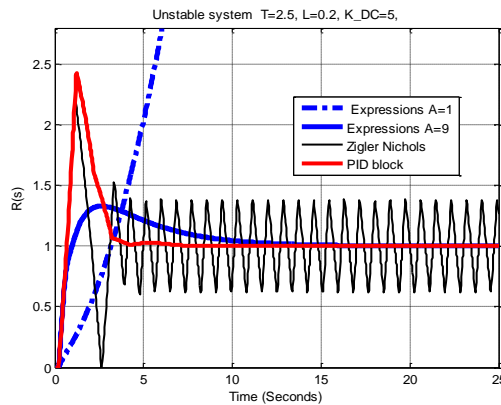

Figure 7(c): Testing control over unstable system.

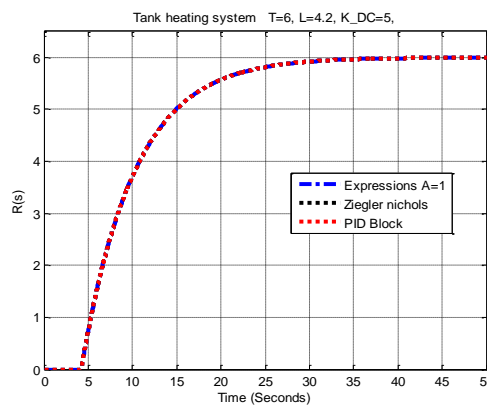

Figure 7(d): Testing control over unstable system.

6. Experimental setup for system identification

To apply the suggested expressions for designing PID-, PI- algorithm, system parameters are needed, namely; T , L , and K_{DC} . To control physical systems behavior in real life, these parameters can be calculated applying system identification process. Referring to Figure 8(a), the identification process to obtain system's transfer function model is performed as explained next:

A sensor is interfaced to control unit board. The physical system is subjected to 100% full step input power value, for example 110V/50Hz VAC or 36 VDC. The changes in the controlled variable (e.g. T , speed or pressure) are

continuously read by sensor, that converts changes into voltage values and deliver it to control unit. Software integration in terms of data reading and processing is applied to record, process and display acquired readings in different forms, including numerical and graphical forms. The graphical form is the physical system’s step response curve, that will have S-shaped curve as shown in Figure 3 up, System parameters L , T , K_{DC} are obtained as shown in this figure also, used to derive system’s transfer function.

In [25][26] the identification process is applied to identify the system parameters and transfer function for the shown in Figure 8(c) Thermolyne 5.8L B1 Muffle Furnace. The obtained response curve is shown in Figure 8(d), the derived transfer function is given by Eq.(19) with system parameters $T=787.5S$, $L=0.2S$ and $K_{DC}=118$ C. These parameters are applied design control algorithm and test the suggested expressions, as well as, compare resulted response with responses when two other design method, Ziegler Nichols and PID auto-tuned block are applied. The resulted graphical response results are shown in Figure 8(e). The control problem was to achieve desired furnace temperature of 1150C smoothly, in acceptable time with minimum error.

Resulted responses show that the expressions and applicable for controlling the furnace system and speed the resulted response by means of tuning one parameter. The resulted response applying the suggested expression with tuning parameter A, is slightly better in comparison when the furnace system were controlled applied the two other methods. Tuning the parameter A, results in improving resulted response speed and reducing error.

$$G(s) = \frac{1118}{787.5 s + 1} e^{-0.2s} \tag{19}$$

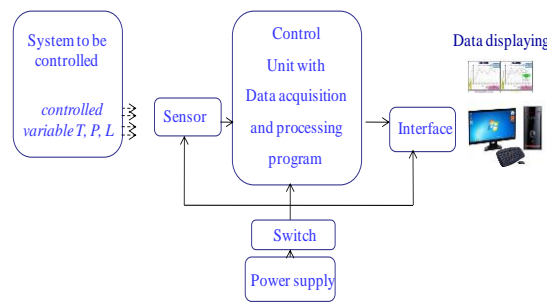

Figure 8(a): The identification process represented using block diagram.



Figure 8(c): Thermolyne 5.8L B1 Muffle Furnace.

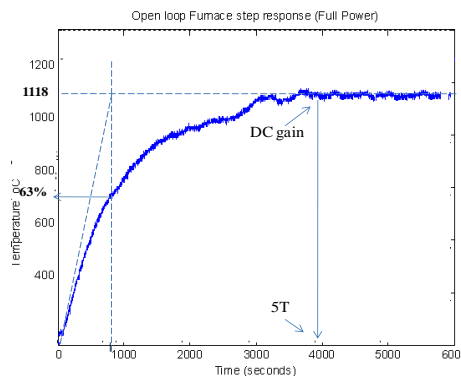

Figure 8(d): Furnace system open loop step response curve applying identification process.

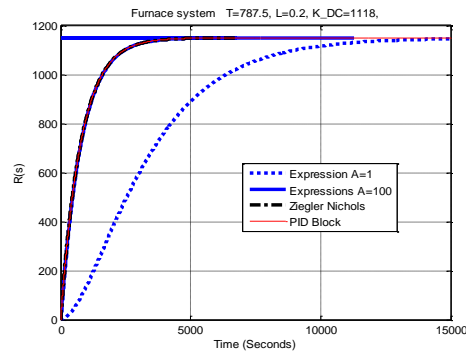

Figure 8(e): Resulted responses applying three design methods.

Conclusions

PI/PID control algorithms are the most commonly applied algorithms for controlling the dynamics of first order systems with time-delay. In present work, a new expression based approach to the design of PI/PID control algorithms for time-delay systems are studied. Based on analysis and evaluation of obtained numerical and graphical experimental simulation results when expressions applied to control various FOSTD systems types, the following can be concluded:

(a) In the present work, are proposed and successfully tested, new linear, simple and easy to use expressions for designing PI-, PID- control algorithms, for controlling the behavior of first order processes with time delay and systems that can be approximated as such.

(b) Expressions are derived to speed up and simplify PI-, PID- control algorithm design process, and to result in overall system response with acceptable output value, acceptable stability, response fastness, minimum observable overshoot, oscillations and steady state error.

(c) the derived expressions, besides being easy to use and apply, are also efficient and successfully tested to control a variety of FOSTD systems including systems with special dynamics, namely, variable time delay process, higher order system approximated as FOSTD, systems with very small and/ or very big time constant, time delay and dc gain values.

(d) Based on analysis of experimental results, the introduced in expression the only soft tuning parameter, was very helpful to improve the resulted response; in terms of speeding up systems response by reducing rise time, settling time, in addition, reduce to minimum overshoot, and error.

(e) Testing results of systems with negative steady state dc gain level K_{DC} , applying Ziegler Nichols expressions will resulted in Inversed response curve. To result in normal response curve, not inversed going down to negative side, any of the next two observations can be suggested : (a) the time delay L, can be given a negative sign and then carrying-on with calculating gains or (c) give a negative sign to all calculated gains and apply these negative values in algorithm design.

References

1. J. G. Ziegler, N. B. Nichols. "Process Lags in Automatic Control Circuits", Trans. ASME, 65, pp. 433-444. (1943).
2. Farhan A. Salem "The Role of Control System/Algorithm Subsystems in Mechatronics Systems Design, Journal of Multidisciplinary Engineering Science and Technology (JMEST), Vol. 2 Issue 10, October. (2015).
3. J. P. Richard. Time-delay systems: an overview of some recent advances and open problems. *Automatica*, 39(10):1667–1694, 2003.
4. Pavković, D., Polak, S., Zorc. D., PID Controller Auto-Tuning Based on Process Step Response and Damping Optimum Criterion, ISA Transactions, Vol. 53, No. 1, pp. 85–96, 2014.

5. Dong, Wei & Ding, Ye & Yang, Luo & Sheng, Xinjun & Zhu, Xiangyang. (2019). An Efficient Approach for Stability Analysis and Parameter Tuning in Delayed Feedback Control of a Flying Robot Carrying a Suspended Load. *Journal of Dynamic Systems Measurement and Control*. 141. 10.1115/1.4043223.
6. G. J. Silva, A. Datta, and S. P. Bhattacharyya. *PID Controllers for Time-Delay Systems*. Control Engineering. Birkh user, Boston, 2005.
7. J. G. Ziegler, N. B. Nichols, Optimum settings for automatic controllers, *Transactions of ASME*, Vol. 64, 1942, pp. 759-768.
8. G. Ziegler, N. B. Nichols. "Process Lags in Automatic Control Circuits", *Trans. ASME*, 65, pp. 433-444, 1943.
9. K. L. Chien, J. A. Hrones, J. B. Reswick, On the automatic control of generalized passive systems, *Transactions of ASME*, Vol. 74, 1952, pp. 175-185.
10. G. H. Cohen, G. A. Coon. "Theoretical Consideration of Related Control", *Trans. ASME*, 75, pp. 827-834. (1953)
11. Saeed Tavakoli, Mahdi Tavakoli, optimal tuning of PID controllers for first order plus time delay models using dimensional analysis, *The Fourth International Conference on Control and Automation (ICCA'03)*, 10-12 June 2003, Montreal, Canada.
12. Astrom K, J, T. Hagglund, *PID controllers Theory, Design and Tuning*, 2nd edition, Instrument Society of America, (1994),
13. Astrom K, J, T. Hagglund, *PID controllers Theory, Design and Tuning*, second edition, Instrument Society of America, 1994.
14. L. Ntogramatzidis A. Ferrante, Exact tuning of PID controllers in control feedback design, *IET Control Theory and Applications*. (2010),
15. S. Skogestad, Simple analytic rules for modelreduction and PID controller tuning, *Journal of Process Control*, Vol. 13, No. 4, 2003, pp. 291- 309
16. K. J.  str m, T. H gglund, *PID Controllers: Theory, Design and Tuning*, Instrument Society of America, USA, 1995.
17. A. O'Dwyer, *Handbook of PI and PID Controller Tuning Rules*, Imperial College Press, London, UK, 2003.
18. A. O'Dwyer, A Summary of PI and PID Controller Tuning Rules for Processes with Time Delay. Part I. In: *Proceedings of the IFAC Workshop on Digital Control: Past, Present and Future of PID Control*, Terrassa, Spain, 2000, pp. 175-180
19. K. J. Astrom and T. Haggglund, The Future of PID Control, *IFAC J. Control Engineering Practice*, Vol. 9, 2001.
20. Fernando G. Martons, Tuning PID controllers using the ITAE criterion, *Int. J. Engng Ed.* Vol 21, No 3 pp.000-000-2005.
21. Katsuhiko Ogata, modern control engineering, *third edition, prentice hall, 1997*.
22. Saeed Tavakoli, Mahdi Tavakoli, optimal tuning of PID controllers for first order plus time delay models using dimensional analysis, *The Fourth International Conference on Control and Automation (ICCA'03)*, 10-12 June 2003, Montreal, Canada
23. Jacques F. Smuts , *Process Control for Practitioners* , Opti Controls Inc ,October 14, 2011.
24. Dana Copot, Mihaela Ghita , Clara M. Ionescu , 'Simple Alternatives to PID-Type Control for Processes with Variable Time-Delay', *Processes* **2019**, 7, 146; doi:10.3390/pr7030146
25. D. Saber , Hamed M. Almalki , Kh. Abd El-Aziz,' Design and building of an automated heat treatment system for industrial applications 'Alexandria Engineering Journal (2020), <https://doi.org/10.1016/j.aej.2020.09.023>
26. Zambaldi, Edimilson, Ricardo R. Magalh es, Bruno HG Barbosa, Sandro P. da Silva, and Danton D. Ferreira. "Lowcost automated control for steel heat treatments." *Applied Thermal Engineering* 114 (2017): 163-169. <https://doi.org/10.1016/j.applthermaleng.2016.11.177>