

Knowledge Organization

Willem Francois Esterhuysen

Institution: University of Pretoria South Africa

IJASR 2021

VOLUME 4

ISSUE 5 SEPTEMBER – OCTOBER

ISSN: 2581-7876

**Abstract:** We show how to use Logical Structures (of ref. [1]) in a variety of settings. It is of use in mathematics to show explicit formal reasoning and especially important in detective work and arguing in a court of law. It is also useful to express knowledge so that someone else can check the correctness of the Structures before and after executing any operators. It is also useful in solving logical puzzles (for pleasure or as a test of mental competence). What we need to do is to fix our thinking to a commonly agreed on symbolisation (words and letters are not clear, precise, varied and focused enough). In some cases there are no "correct" ways to symbolise so these are treated on a first come first serve basis. Logical Structures are graphs with singly or doubly labelled vertices and labelled (by symbols) edges. The levels of reasoning are of special importance and are made explicit. They are of great help in reasoning correctly. We prove AND introduction, and other "axioms" of propositional logic using properties of Attractors and Stoppers. Other axioms of propositional logic can also be proved. We note that all the axioms of Zermelo-Fraenkel set theory can be expressed entirely in symbols of Structural Logic.

**Keywords:** Structural Logic, Knowledge, Structured Information

Highlights: The proof statements.

Declaration: I have nothing to declare

**Introduction:**

We start with a review of the basics and the nature of Structural Logic (SrL). SrL uses graphs with doubly labelled vertices and labelled (with symbols) edges. The double labelling is accomplished by allowing the vertices to be 2-dimensional enclosures that can have letter, word or symbol content. We prove AND introduction using axioms of the Attractor and Stopper operators. We show why OR introduction is invalid. We also prove (the correct version of) AND elimination. Also shown is why dropping Stoppers anywhere in a structure is invalid. We show how to construct new structures from old ones. We show why rotation of an Attractor through 180 degrees is invalid. We show that there is a left to right bias in SrL. We give axioms from ref. [1] special names. We show the truth table for "therefore" which is in my opinion closer to how we reason in mind - two entries are not used. We show that a theorem of Classical Logic cannot be proven using Structural Logic axioms. We state a "collapse"- Inference Rule. We show it is fixed that "AND" takes priority over "therefore". We show that the "set" of all sets that do not contain themselves is either not a set or, if it is then, Mathematics doesn't exist. We show how to prove an "axiom" of Stage Theory. We show that an axiom of Zermelo-Fraenkel set theory can be stated entirely in symbols - very elegantly. If every statement cannot be stated entirely in symbols then your symbolic language is not adequate. SrL is adequate since you can just put words in concept- or object enclosures. Then we examine how SrL works in a variety of situations.

Definition: An *object* is a name for sense-data. A *concept* is an object that is the result of some relation between objects.

Methods: good old reasoning.

Results: various results are in the discussion.

Chapter 1: The Basics

Chapter 2: Sample Arguments, Proofs and Usage of Knowledge

Appendix A: Operator List

Appendix B: Relation List

Appendix C: Enclosure List

Bibliography

Chapter 1: The Basics

**Discussion:**

The book in general tries to explicate (or make explicit) the process of constructing structures from text in as many circumstances as possible. Constructing the structure with enough interlinkages makes possible actual usage of the knowledge. A knowledge structure has at least one operator. The book also tries out (and formalises) proofs in a varied range of other Logics as translated into Structural Logic (**SrL**). This book relies on my other book ref. [1]. There is another Logic called Structural Logic (**SL**), but this (**SrL**) is not it.

The main purpose of the book is to make possible the expression of knowledge as it appears in mind, for purpose of comparison so we can check each other's reasoning and learn from one another.

To show where it fits in: Knowledge Structures are graphs with edges labelled by symbols and vertices singly or doubly labelled, with at least one operator in the structure. The double labelling is accomplished by allowing the vertex to be some kind of 2D enclosure that can have words or letter "content".

We are going to use Structure enclosures. In my view propositions are objects relevant to concepts or object-concept-object (the first object is called "subject" in natural language terminology) structures.

The following structure (graph):

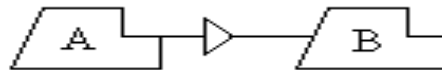

Structure 1.1

Reads: "Structure A therefore structure B". The default meaning is: "Structure A exists therefore Structure B exists". And "exists" entails "is true if all operators are executed". A *connective* is an operator that is already executed (the edges of the graph). The "therefore" link above is an operator that is already executed. An *operator* is an edge, with symbol with no underlying meaning but which can transform a structure. Examples of operators are: Introductors, Attractors, Stoppers (symbols to follow).

We are going to explore to find the actual argumentation/deduction that happens naturally in mind, and give it symbols. This reasoning would happen in your study, and in ordinary life the logic is mainly: A connects with B causing C. The "connecting" could be physical or informational.

Someone said Mathematics uses Classical Logic (**CL**) and good taste, and this is what we stake our lives on sometimes when we utilize some engineered object. However Engineering Mathematics does not include the more general ideas used in advanced Mathematics (Group Theory, Category Theory).

The scope of a structure is expressed as a non-empty vertex drawn as follows:





Where the dots say the enclosure is not empty. In this book whenever a structure does not have a scope enclosure we assume the scope is **SrL** itself. A scope enclosure is assumed relevant to every enclosure in a structure.

Chapter 2: Sample Arguments, Proofs and Usage of Knowledge

In order for **SrL** (system S0) to be compatible with Natural Deduction (**ND**) we must add the prior rule or axiom that statements with Stoppers carrying OR-links cannot be rearranged at any stage of a proof sequence otherwise we could conclude "A AND B" from "A OR B" which is not valid in **ND**. S1 is a system of **SrL** where stoppers can be dropped anywhere in a structure. S1 is not compatible with **ND**? I mean with "compatible" that sentences from **ND** may be taken as statements in **SrL** where each object is taken as a structure and that statements of structures in **SrL** can (in some cases) be taken to sentences of **ND** just with structures taken as objects. Also: what provable in **ND** is also provable in **SrL** system S1. Objects in **ND** can also be expressed as objects in **SrL** and sentences as either general names in structure enclosures or names in structures of other enclosures.

We first prove AND introduction using two structures:

2.0 Theorem (T:ANDI):

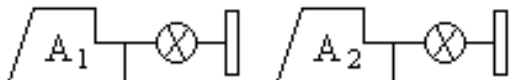
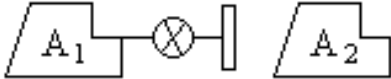
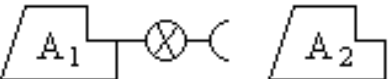
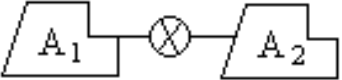
Line #	Statement	Reason
1		Premises
2		1, A:AtI
3		2, A:ASS
4		3, A:SD in S0
5		4, A:ASS
6		5, T:AL

Structure 2.0

The operator in line 4 is called a Stopper and the one in line 5 is an Attractor. Their axioms are stated in ref. [1]. See after Structure 2.33.3 for the meaning of the abbreviations in the reasons. For T:AL see the paragraph after Structure 2.0.1.

Note that by the same reasoning OR introduction is also valid. We need some a priori rule to exclude this, so it can rhyme with Natural Deduction. The rule is: since the truth table for "exist together" and "OR" does not agree: OR introduction is not valid. In fact we can introduce any relation this way, provided its truth table agrees with "exist together" - the default relation. Classical Logic needs AND introduction to be allowed by a special inference rule. We prove AND-elimination as follows:

2.0.1 Theorem (T:ANDE):

Line #	Statement	Reason
1		Premise
2		1, A:AtI
3		2, A:AD
4		3, A:ASS
5		4, A:SD in S0
6		5, A:ASS
7		6, Split
8		6, Split
9		8, A:SD in S0

Structure 2.0.1

and we are rightly left with the two structures on separate lines. "7 and 9" means the same as the premise. We note that it would be a serious error to leave one of  $A_1$  or  $A_2$  out if one of them would provide a contradiction. The "Split" is just valid for a Stopper carrying an AND relation. The same can be done with OR instead of AND but it is not valid for one of the structures is false. Some books leave out  $A_1$  or  $A_2$  and call the result AND-elimination. This is wrong. 5 therefore 1 is also inferable (T:AL).

We can prove the "axiom":  $(p \text{ OR } p) \rightarrow p$ . There is a problem with this "axiom" since it requires two operations.

We prove  $(A \text{ OR } A) \rightarrow A$  as follows:

Line #	Statement	Reason
1		Premise
2		1, A:AtI
3		2, A:AD
4		3, A:ASS
5		4, A:SD in S0
6		5, A:ASS
7		6, Split
8		6, Split
9		8, A:SD in S0

Structure 2.0.2

We prove "Contradiction":

1 (p AND (p -> (q AND (not q))))	Premise
2 (q AND (not q)))	1, T:MP
3 not p	2, follows from contradiction

Where line 3 follows, since anything follows from a contradiction, and we used the theorem: Modus Ponens (proved in ref. [1]). We work in letters if the concepts don't need clarification by symbols.

With the following axiom (how attractors go into structures in a structure):

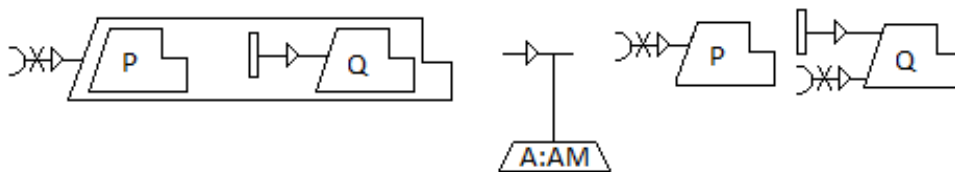

Structure 2.0.3

We can prove contraposition ((P -> Q) -> (not Q -> not P)), by contradiction. We assume the negative and proceed as follows:

Line # Statement

Reason

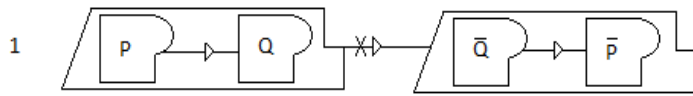

Premise

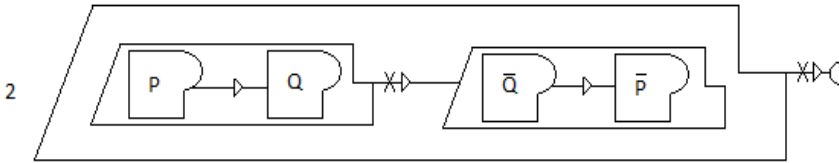

1, AtI

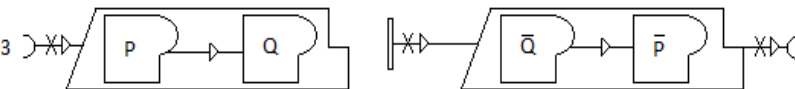

2, A:AD

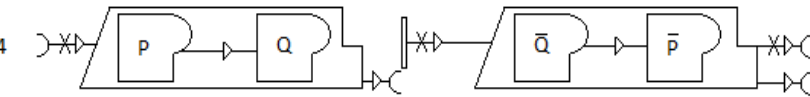

3, A:AtI

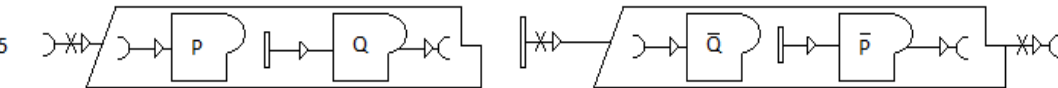

4, A:AD

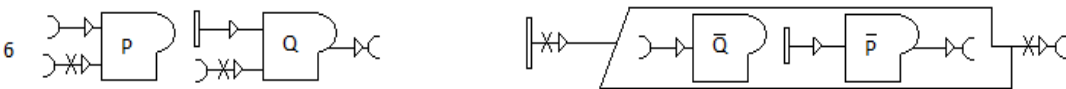

5, A:AM

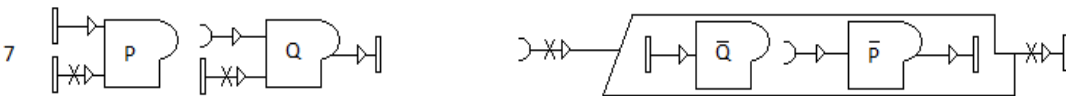

6, A:ASS

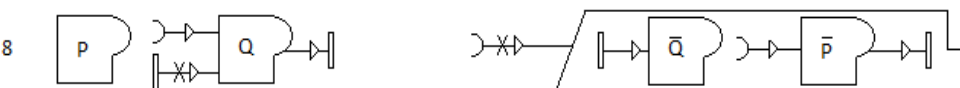

7, A:SD in S0

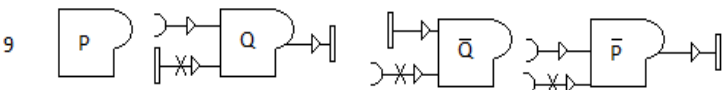

8, A:AM

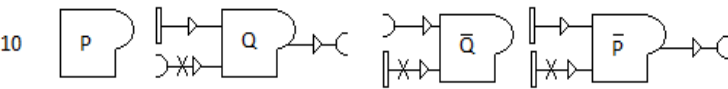

9, A:ASS

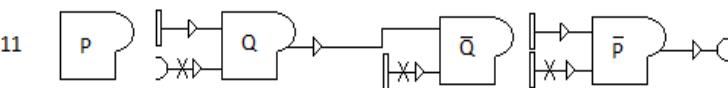

10, A:AL

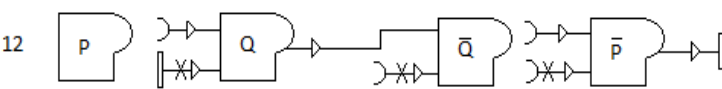

11, A:ASS

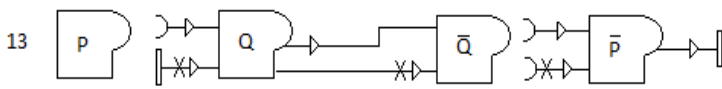

12, T:AL

Structure 2.0.4

And we have a contradiction in line 11 (inside a sentence), so this proves contraposition. We have: "Q therefore and not therefore not Q", and this is a contradiction. Here the enclosure of P is called a Proposition Enclosure. The other Attractors and Stoppers won't take away the contradiction. Isn't it amazing that we could derive a contradiction? We must be doing something right.

We can prove association  $(A \leftrightarrow (B \leftrightarrow C)) \leftrightarrow ((A \leftrightarrow B) \leftrightarrow C)$  as follows:

Line #	Statement	Reason
1		Premise
2		1, A:AtI
3		2, A:AD
4		3, A:AtI, A:AD
5		4, A:ASS
6		5, SD in S0
7		6, A:AM

Structure 2.0.5

Now in line 7 we can choose the Attractor of the top Operator Priority Operator (carrying the 2) to connect B with C. We can then do an A:ASS and link B using the resulting Attractor to A: this operator has Operator Priority 1 (implicitly: from it's source). The relations are "bi-directional implication". The proof continues:

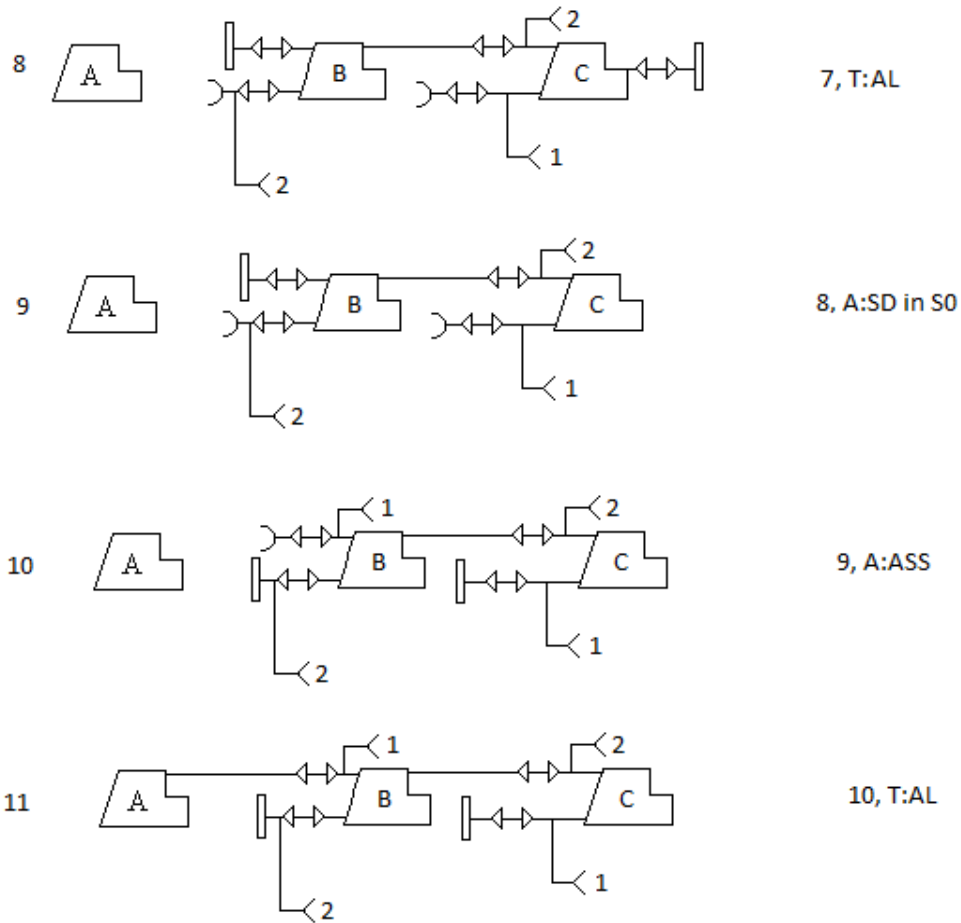

Structure 2.0.6

Now we may drop the Stoppers because they would just give us the premise anded together with the conclusion. This is equivalent to doing T:ANDE to prove the identity. Note that the same applies for all the other relations that we will define.

Syllogism is proven in ref. [1]. The "axiom":  $p \rightarrow (p \text{ OR } q)$  can be proven using "AND elimination", "Contraposition", "De Morgans Law" and the following law (Structure 2.0.7).

A rule not easy to express in letter Propositional Logic is:

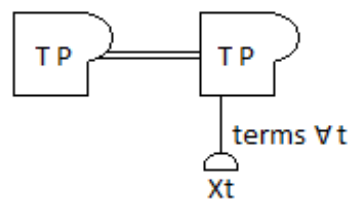





Structure 2.0.7

It states that for all terms t in a proposition TP if we replace t with not-t the formula truth table stays the same if TP is a tautology. Here the operator attached to TP is called an Introducer and the relation is "equivalence". The proof

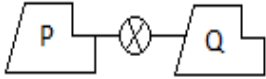

is: replacing terms by their negation mirrors the truth table around a horizontal axis. Since the top and bottom parts are all "True" the reflection leaves the table invariant.

We can try to prove commutation:  $(p \text{ AND } q) \rightarrow (q \text{ AND } p)$  by assuming the premise and then doing T:ANDE and then T:ANDI in the opposite order as follows:

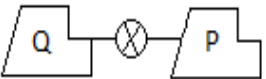
Line #	Statement	Reason
1		Premise
2		1, T:ANDE
3		1, T:ANDE
4		3,2, Unsplit
5		4, T:ANDI

Structure 2.0.8.

There are two more axioms of how Attractors and Stoppers behave:

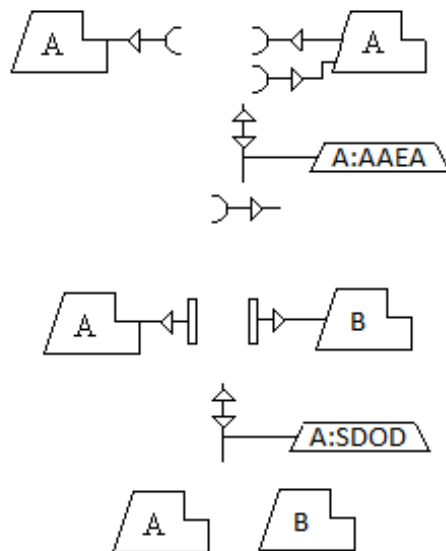

Structure 2.0.9.

Note well the direction of the "therefore" symbols. The labels read: "Attractor Annihilation Extra Attractor" and "Stropper Drop Other Direction".

With these two axioms we can prove the "axiom":  $(p \rightarrow r) \rightarrow ((q \rightarrow p) \rightarrow (q \rightarrow r))$  by reasoning backwards through the following proof:

Line #	Statement	Reason
1		Premise
2		1, A:Atl
3		2, A:AD
4		3, A:ASS
5		4, A:SD
6		5, A:Atl
7		6, A:AD
8		7, A:AM
9		8, A:AAEA
10		9, A:AM
11		10, A:SDOD
12		11, T:AL x 2
13		12, A:ASS
14		13, A:SD
15		14, T:ANDE

Structure 2.0.10

Line 12 follows since structure R with its two Attractors constitutes a structure.

We next show that one cannot derive: A AND B from (A AND B) OR (B AND C):

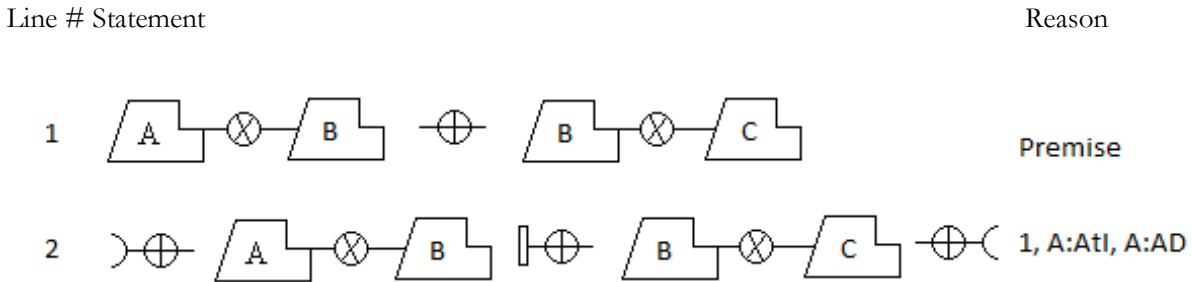

Structure 2.0.11

And we see that even though we can get rid of structure B we can not get rid of the bothersome Stopper carrying an "OR" relation.

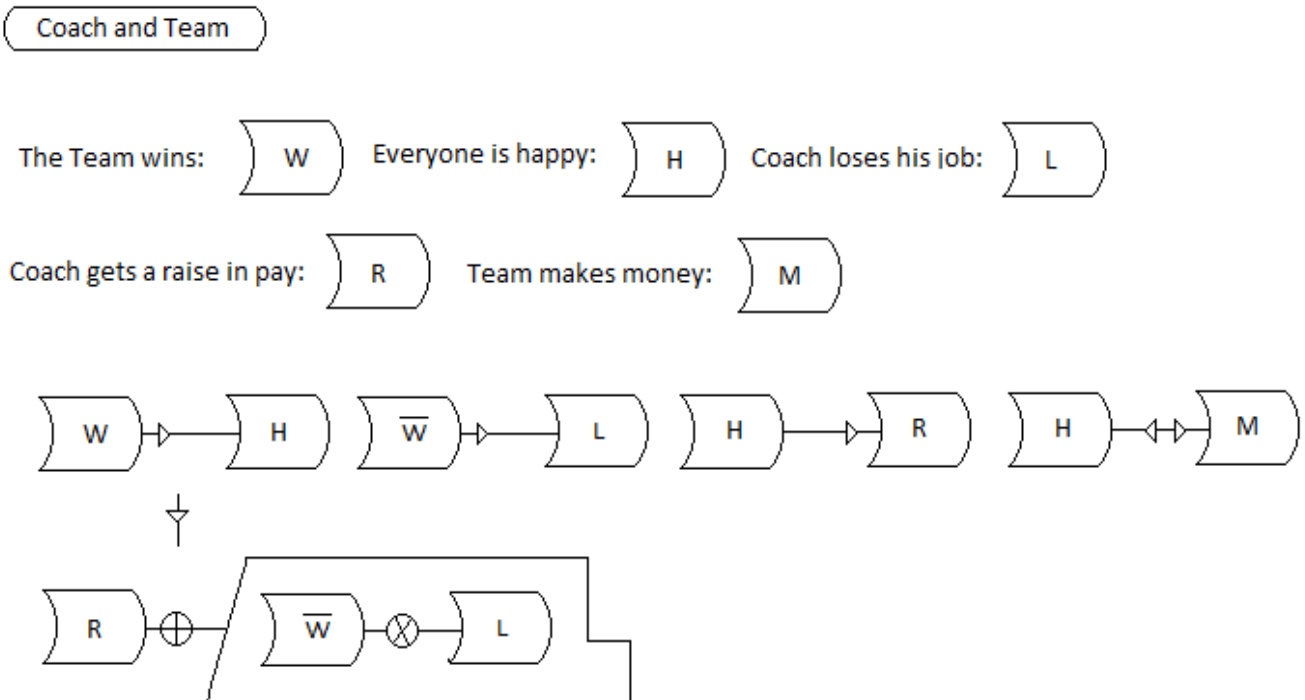

SrL is good for drawing conclusions as the following example shows. We quote a problem from ref. [5]: "If the team wins, then everybody is happy. If the team does not win, then the coach loses his job. If everyone is happy, then the coach gets a raise in pay. Everyone is happy if and only if the team makes money. Hence, either the coach gets a raise in pay, or the team does not win and the coach loses his job." This is to be symbolised as follows:



Structure 2.0.12

The enclosure of W is a "Concept Enclosure". The conclusion follows from: (W OR not W). Replace Left Side "W" with "H" and "H" in turn with "R" by syllogism. Then Right Side can be replaced with "not W AND L", since "L" follows from "not W".

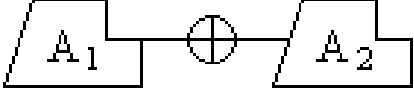
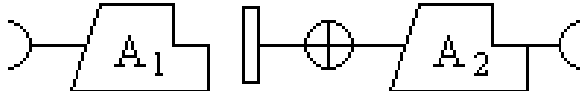
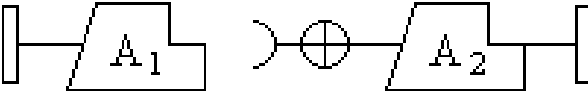
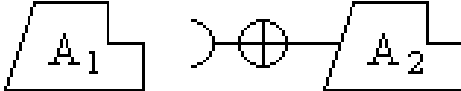
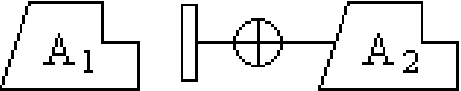
The following "proof sequence" show where the problem with S1 arises.

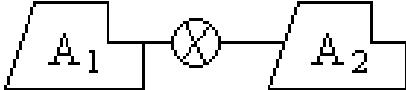
Line #	Statement	Reason
1		Premise
2		1, A:AtI, A:AD
3		2, A:ASS
4		3, A:SD in S0
5		4, A:ASS
6		5, A:SD in S1
7		6, T:ANDI

Structure 2.1

We see that if we are in S0 we would be stuck at line 5 with only trivial manipulation possible. In line 2 we introduced and distributed Attractor operators which breaks the OR relation and a Stopper then attaches to the OR relation.

### 2.31 Definition

The definition of when ideas/objects/object-concepts/object-concept-objects are *relevant* to each other is: if the structures can fit in some context that fall under the same scope. Note that [1] does not use "therefore" to define the other connectives "AND" and "OR" and then defines "therefore" by Modus Ponens (MP). Also MP is proven by just using the properties of Attractor and Stopper operators! We are also, however, forced to distinguish two forms of "follows from" as the undefined one that comes out through the behaviour of operators on formulas and the "therefore" of natural language (characteristics on the page after structure 2.122). The first one is context independent (premises have no context or the relation does not recognise it) while the latter is not. We can now, without circularity, define "AND" and "OR" using the former "follows from". Therefore is symbolised in this book by a triangle or a triangle on a line pointing to the conclusion. "follows from" is symbolised by a triangle with a line at its base (from ref. [1], see Appendix B for the symbol). This also symbolises "is provable that". I subscript it with the name of the logic when needed.

2.32 Definition

An *idea mesh* is a 2-dimensional plane of outlines in which unique ideas fit. It looks like a jigsaw puzzle. The planes can slide over each other so that idea outlines can overlap exactly. Now *A not-therefore B* can be defined as: no idea relevant to B is on a mesh overlapping exactly with any idea in the mesh containing an idea relevant to A. This requires idea meshes to have an outline and to be totally fillable with ideas. All ideas under some sub-scope fits on the same idea mesh. There is a large hierarchy of sub-scopes. A *complete* structure is a structure with a scope enclosure. A well-formed structure is a structure satisfying:

- (1) If A is an enclosure (with or without contents) then A is a structure
- (2) If A1 and A2 are structures, so are:

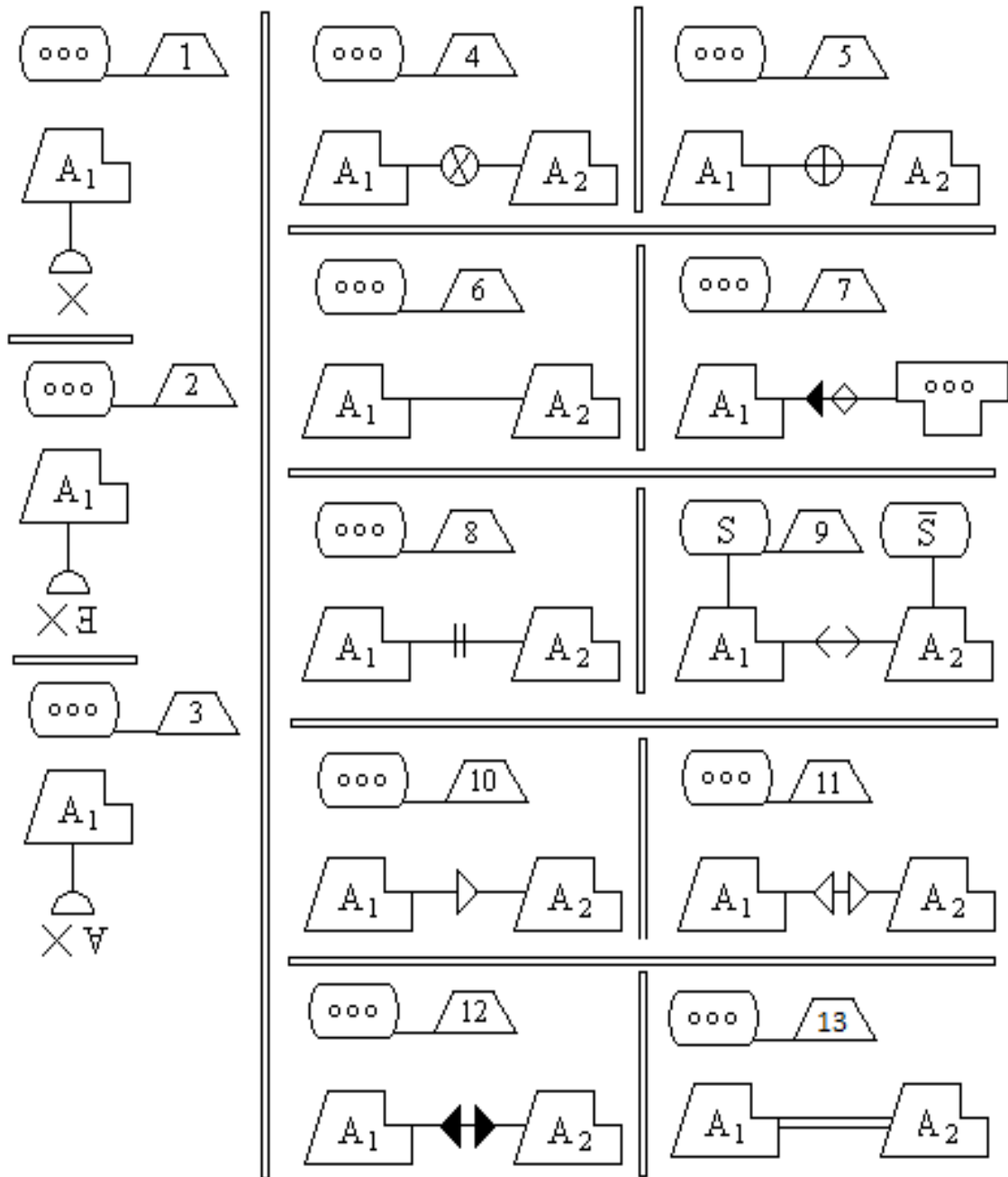

Structure 2.32

Where all are subject to usage rules of ref. [1]. This is also valid for structure enclosures with different names. We also allow other structures if they have a meaning in natural word-language. Note that the above constructions do not necessarily take true (valid) structures to true (valid) structures. Interpretability is the test we use to determine (truth) validity of a structure. Structures with all operators executed in them are true/false while structures with operators are a valid/invalid deduction of another structure.

The structures above read:

1. Negation introduced into structure A1.
2. Not some introduced into A1.
3. Not All introduced into A1.
4. Structure A1 AND A2 is true.
5. Structure A1 OR A2 is true.
6. Structure A1 is relevant to A2.
7. Some enclosure (non-empty) may be imported into structure A1.
8. Structure A1 has some relation with A2.
9. Structure A1 stands against A2, with either in the complement scope of the other.
10. Structure A1 therefore A2.
11. Structure A1 if and only if A2.
12. Structure A1 is defined by A2.
13. Structure A1 is equivalent to A2.

The same goes for negation introduced into the relations above.

So far **SrL** has only a single axiom scheme: "Structure An exists". The proof of MP by Metalogic a mean (see ref. [6]) presuppose the idea of "satisfaction" and is a bit suspect since a formula may be satisfied yet not provable in the system (incompleteness). **SrL** does not claim completeness.

The reader may complain that **SrL** is too tedious to draw. That is not true since it amounts to copying and pasting on a computer.

Scope enclosures may be defined as the symbol we need to limit our possible World and it can be seen as not having a meaning, but is only an organizational device. What other texts call "predicates" are modelled in **SrL** using concepts relevant to objects. Sometimes when the logic allows (warrants) it we may include the target object in the concept.

We have the rule: AND Elimination: "AND-E" in Classical Logic (**CL**). This rule is not entirely correct. Look at ref. [10]. It says that A (inferred from A AND B) is a weaker statement than "A AND B". This should be included in the logical terminology as a check in a checkbox named: "check the context for weakening". This checkbox should be displayed next to the reason for the inference as: AND-E [x] and every inference that depends on this line of the proof should inherit the state of the checkbox. Most of the time this will have no effect on the validity of the inference obtained, but on interpreting, the weaker context must be looked at and the checkbox changed to [y] if the weaker context is still in a state close enough to the assumption's context. When no interpretation is done the box should be kept at [x] and later one can look at a collection of arguments with checkboxes in x state to determine a truth about the reasoning system itself. The same goes for OR Introduction: "OR-I". This is where the non-truth functional sense of OR comes in. This checkbox is irrelevant if the proof was by contradiction. **SrL** endorses these two variants of rules in order to get closer to **ND**. For mathematics this is no issue since the interpretation is always objects in a set.

This way one doesn't have to introduce another AND and OR, and both **CL** and Relevance Logic (**RL**) proponents can use **SrL**. **CL** proofs can just be updated with a checkbox if necessary. Also indexes on lines of a proof like in relevance logic are now unnecessary.

To **symbolise an argument** we proceed as follows: (basically use the inverse of the method of ref [1])

1. Find a scope for the structure by inspection of the terms,
2. Find a sub-scope that restricts translation (based on what our problem is),
3. Give temporary letter symbols for the terms of the argument,
4. Put the terms in enclosures and relate them with symbol relations (restricted by 1, 2).

We translate back to words by leaving out all the structural terminology.

**2.33 Theorem**

Lewis's deduction of "any proposition follows form a contradiction" is correct.

**Proof:**

His proof uses AND-E without checking the checkbox and clearly, not checking the required context after he made his conclusion can result in an absurd statement. His argument reaches the conclusion: If Socrates is a man and Socrates is not a man then Socrates is a stone. However since now only conclusions still under the scope-anti-scope (see definition 2.122) pair of the contradiction would still be valid, we have "being a stone" in the anti-scope of "being a man" so that our context checks out and the conclusion is valid. QED.

There is a problem with this statement, since one can now say: "Socrates is a man and not a man, so Socrates is a stone". But we know that Socrates is a man. So a statement may logically follow, but still not fit with existing knowledge. But I surely don't think up contradictions before thinking an original thought.

We try to prove the following theorem. See the following structure ("Theorem" 2.33):

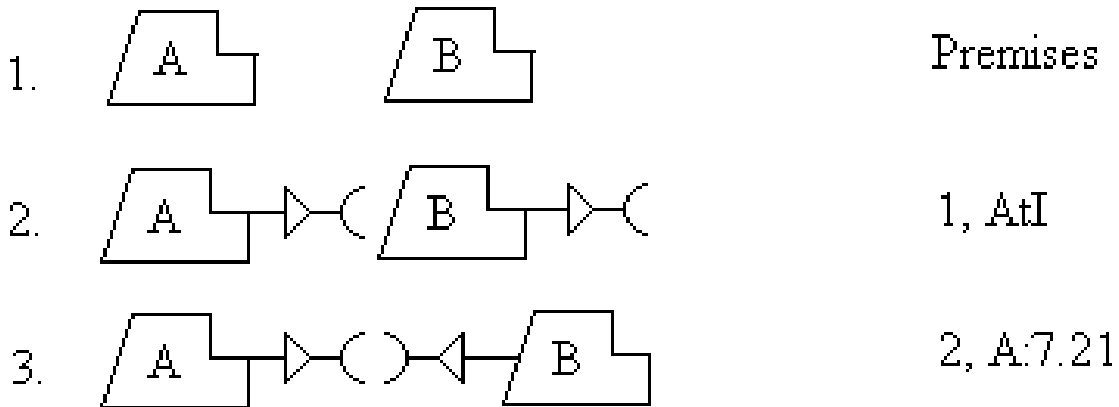

Structure 2.33

And we can only continue to reason with this trivially. Here we used the "turn trough 180 degrees" Inference Rule (IR) in line 3. It is invalid in for just one attractor occuring on one structure. Line 2 uses Attractor introduction, with the Attractors carrying "therefore" symbols as the IR specifies.

In fact A:7.21 is invalid since we can then derive B -> A form A, B.

One can infer A -> B from A, B in S0 as follows (Theorem 2.33.1):

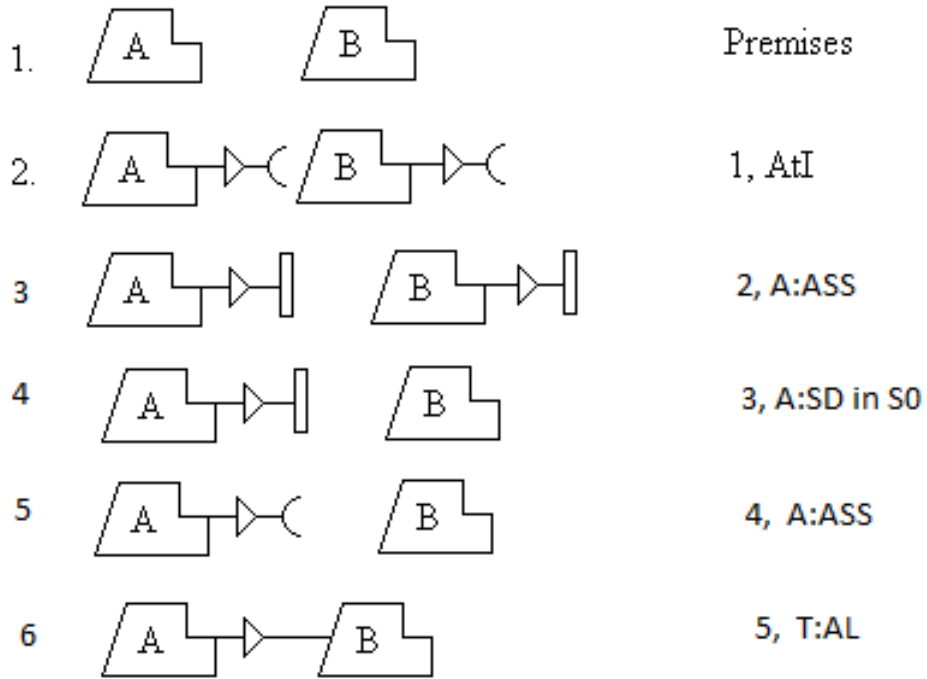

Structure 2.33.1

I see no problem with this. Note that the full truth table cannot be used as it isn't the same as that of the "exist together" relation.

One can not infer  $B \rightarrow A$  from  $A, B$  in  $S0$  since this would require the premises in the opposite order. Hence there is a left to right bias:

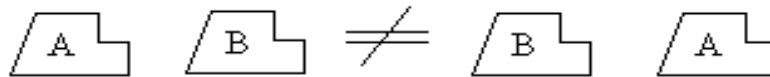

Structure 2.33.2.

One would think the following is valid:

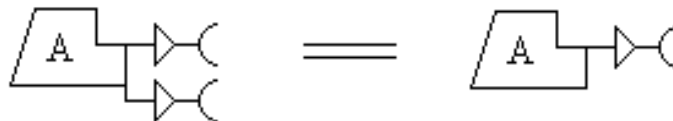

Structure 2.33.3

Since two therefore symbols should go to just one. In fact it is invalid because it allows us to drop a stopper anywhere in a structure in a roundabout way.

We give special IR's from ref. [1] special names:

- A:7.1 = Attractor Introduction = A:AtI
- A:7.2 = Annihilation = A:A
- A:7.3 = Attractor Distribution = A:AD
- A:7.5 = Attractor Linking = A:AL



A:7.6 = Attractor/Stopper Swap = A:ASS  
 A:7.8 = Stopper Drop = A:SD in S0/S1  
 A:7. = Collapse = A:C

It may happen that more than one Attractor must be distributed (see for example Structure 2.34). In this case the Attractor carrying the symbol for the main connective must be distributed first (it may happen that a structure has no main connective in which case we need first to take substructures out of the structure with just two enclosures and a relation, but with it's context kept in mind). Context is the scope and a structure of sub-ideas, where a sub-idea is like an idea that can fit into a mesh but it can hook onto many ideas. Sub-ideas don't have word names and are obscure. I will use the relation "direct link" to represent such hooking together of ideas by sub-ideas. In **CL** the main connective is the connective outside the most of brackets or a quantification operator "connective".

For the validity of our IR's see: 2.182 Soundness of SrL.

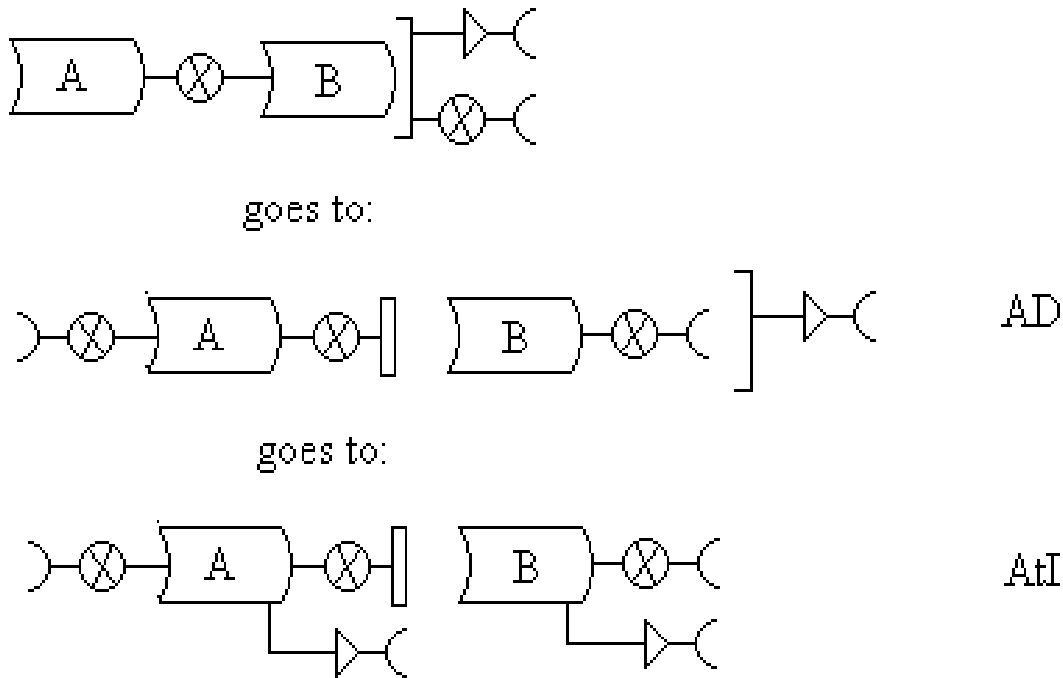

Structure 2.34

Here it would be erroneous to have distributed/introduced the Attractor carrying the "therefore" first - then only one attractor carrying "therefore" would have attached to concept B.

According to me the statement  $A \rightarrow B$  has the following truth table:

A	B	$A \rightarrow B$
T	T	T
T	F	F
F	T	X
F	F	X

where the X's indicate irrelevance (for the subsystem of **ND** compatible with **SrL** system S1). This is where special care should be taken with S1's theory. However given: not  $\neg A \rightarrow B = A$  is true and  $\sim B$  is true we get not  $\neg \neg (\sim A \text{ OR } B)$  by De Morgan's theorem which should go to  $\neg \sim A \text{ OR } B$  (if negation is redistributable over the "is provable that" symbol), in which case the full table above is valid (T in X's place). As stated later I think the above table is safer (closer to how we reason in mind).

In **ND** it is provable that from  $A \rightarrow (B \rightarrow C)$  one can infer  $(A \text{ AND } B) \rightarrow C$ . In **SrL**, system S1 we can only prove:  $A \text{ AND } (B \rightarrow C)$  (after other rules appended to **SrL** S1 we can prove this) as follows:

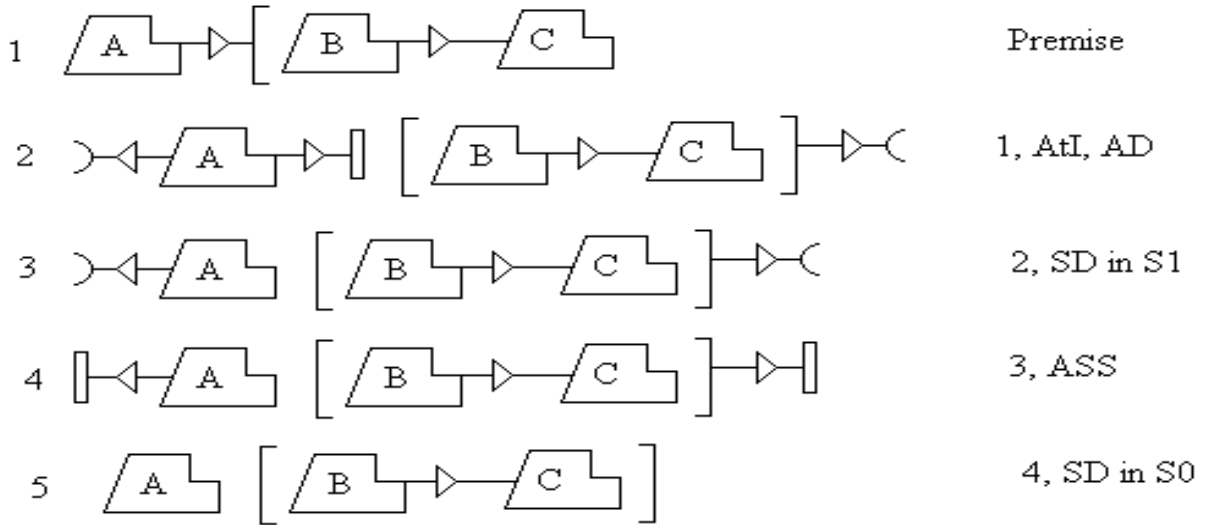

Structure 2.35

And one application of AND-Introduction (see structure 2.137) leads to the stated result. It should be noted that these two have nearly the same truth table. The truth table is:

A	B	C	(A AND B) -> C	A AND (B -> C)
T	T	T	T	T
T	T	F	F	F
T	F	T	X	X
T	F	F		X
F	T	T	X	F
F	T	F	X	F
F	F	T	X	X
F	F	F	X	X

Not quite the same. We must accept that S0 is not a super-language of **ND** since one cannot prove the theorem in S0. It is a sublanguage however. Hence there is true statements which cannot be proved in S0. Ref [6] has  $A \rightarrow (B \rightarrow C) \vdash (A \text{ AND } B) \rightarrow C$  as a theorem. S1 gives a richer number of theorems provable than S0. We could make the **intuitive rule (A:IRel)** that any introduced relation should be introduced at operator priority (o.p.) = maximum. Implementing this we would have the same theorem after line 5 and T:ANDI.

The "Collapse" IR is shown next:

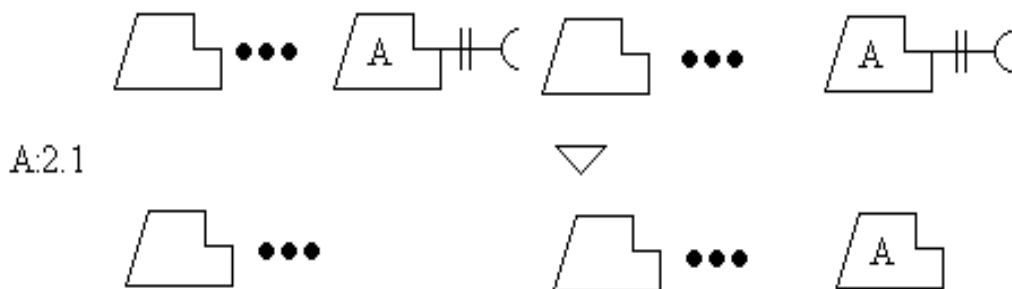

Structure 2.36

Here we specify that the symbol carried by the Attractors should match and that the collapse is onto the rightmost occurrence of the statement.

We have that structures cannot be rearranged in any line of a proof

A case where the same statement can be derived in S0 And ND is stated: From (D AND E), (D -> F) AND (E -> G) we can infer F AND G. The proof is straightforward. In S0 we cannot prove the same as in S1. Note that I do not mean by "S0 is compatible with ND" that everything provable in ND is also provable in S0, only that the rules of ND applies to statements in S0 just with structures taken as objects and that we can take statements of ND into S0, just with objects taken as structures.

We prove this starting with the following two premises:

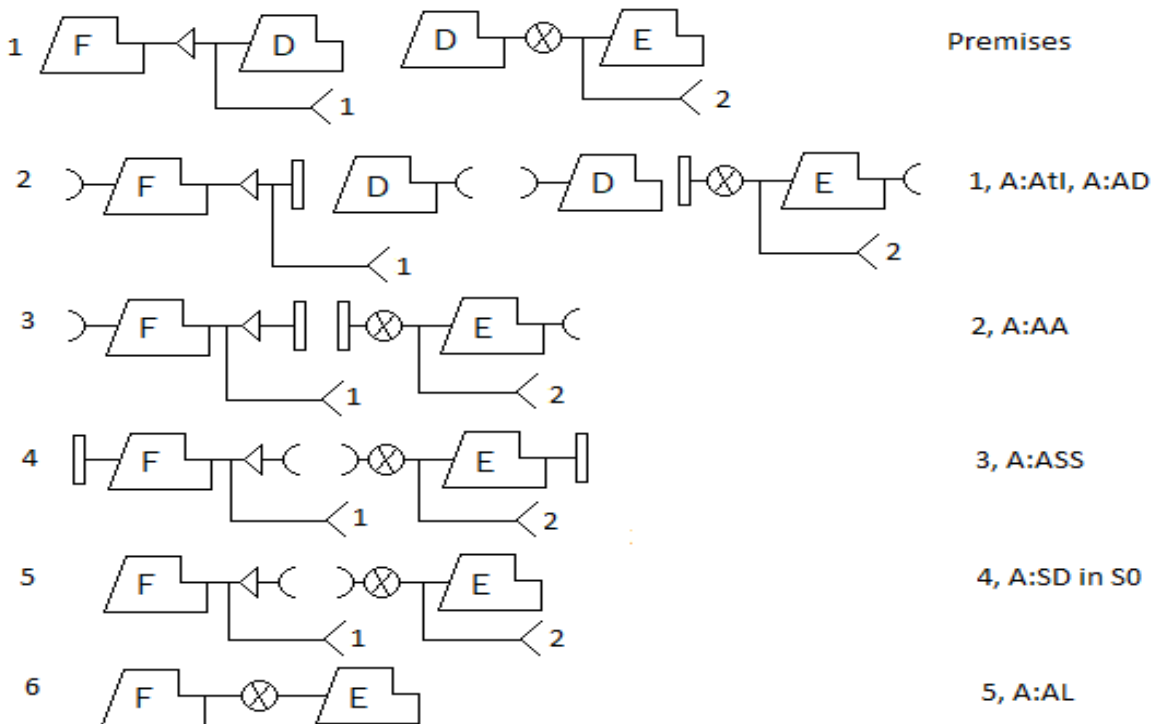

Note that (line 5 -> 6) "And" took priority over "therefore". When an attractor does not carry a symbol we assume it can break any relation. Similarly we can prove that from "F And E" and "E -> G" we can infer: "F And G" as required. Thus it is fixed that "And" takes priority over "therefore". The abbreviations for the reasons are form [1].

Some formal system axiom(s) are provable in SrL. For example: in Stage Theory (see [3]) the axiom called: "Order" can be proven in SrL. It is stated as:

$$\forall r \forall s \forall t (r < s < t \rightarrow r < t)$$

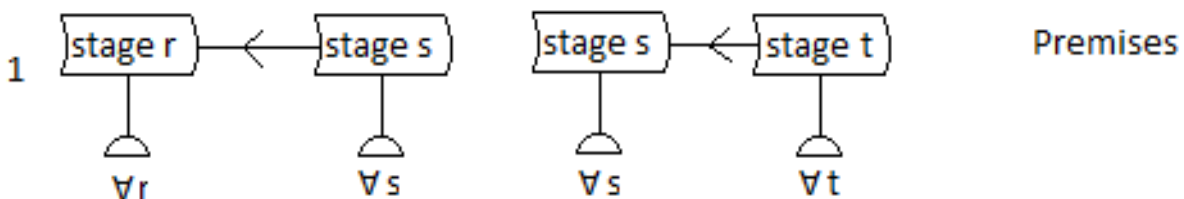

and can be proven from the premises by the same method as that used to prove Syllogism (see [1]). Therefore all axioms stating transitivity can be proven in **SrL**. The enclosures in the structure are "concepts" and the relation is "<".

For the reasoning around the first axiom of Zermelo-Fraenkel set theory there is a unrecognised implication. The axiom (ref. [4]) as translated into **SrL** is:

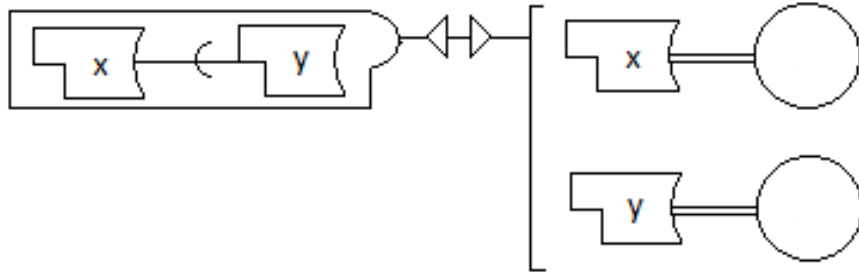

Structure 2.36.1.

It reads: x is an element of y is a proposition if and only if x, y exists as sets. This is so since the enclosure on the left is a Proposition Enclosure. It is statable entirely in symbols! In fact all the axioms of this Set Theory can be stated entirely in **SrL** symbols!

Then he goes on to mention a counterexample of a set (the "set" u):

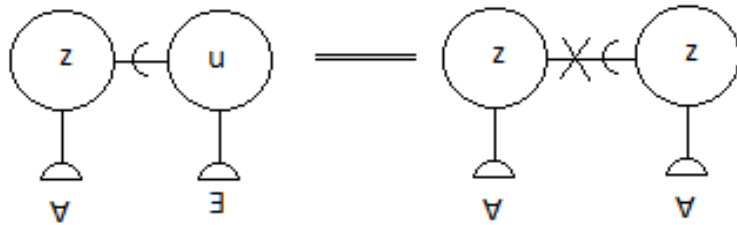

Structure 2.36.2.

Look how elegant this is! z is quantified away.

He then goes on to prove:

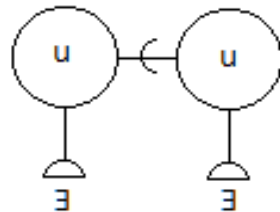

Structure 2.36.3.

is not a proposition by proving it is neither true nor false.

He then should have concluded: ""element of" does not exist or "u is not a set"" i.e. LS of the axiom is not a proposition, because the negation of the axiom on both sides is true. He skipped this step. Because the axiom implies "element of" exists we can conclude "u is not a set". Therefore we have that if u is a set then Mathematics does not exist, because one of its axioms is then false!

In order to prove an axiom of Level Theory from ref. [3] we need the following axiom:

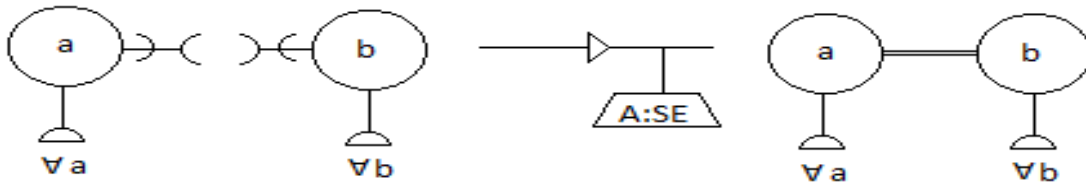

where the symbol carried by the Attractors on the left side is meant to be "is an element of", just facing in opposite directions. The circles are Sets. Then the "axiom":

$$\forall a \forall b (\forall x (x \in a \leftrightarrow x \in b) \rightarrow a = b)$$

can be proved as follows:

Line #	Statement	Reason
1		Premises
2		1, A:AI, A:AD
3		2, A:AA
4		3, A:ASS
5		4, A:SD
6		5, A:SE

technically the premises is not the same as left side of the formula, but the default relation is "exist together" and its truth table agrees with that of "bi-directional implication". The enclosures carrying name "x" in line 1 are Objects.

Ref. [6] says that Modus Ponens (MP) is provable in Metalogical language. This is supposed provable by assuming the negative and deriving a contradiction. We use P and Q to represent sentences.

1	$P \text{ AND } (P \rightarrow Q) \not\equiv Q$	assp
2	$\text{SI}(\text{I}[P \text{ AND } (P \rightarrow Q)] = T \vee \text{I}[Q] \neq T)$	1, SV
3	$\text{J}[P \text{ AND } (P \rightarrow Q)] = T \vee \text{J}[Q] \neq T$	2, exs (J particular)
4	$\text{J}[Q] \neq T$	3, cnj
5	$\text{J}[P \text{ AND } (P \rightarrow Q)] = T$	3, cnj

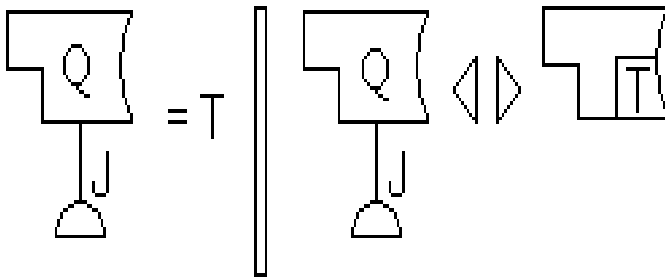

Derivation 2.37

where the down arrow represents Metalogical "and", the symbol in line 1 means "it is not provable that", "= T" means: "is true" and "SI" means: "there is some interpretation I". The reasons are defined in ref [6]. Actually Metalogical "and" is not elegant since it already exist on level 2 of reasoning as: Logical "and" and mirroring it on level 3 is in my opinion circular (or it does not carry over into level 3). For just what these three levels are see paragraph after structure 2.65.4. "Q" is in an Object Enclosure with an Introductor attached.

We symbolize interpretation J of Q: "J[Q]" using an Introductor as shown above. Where the object with the T in it is True if the object Q exists as the interpretation requires (object-truth) i.e. the object exist in the possible world specified through J. Note that the object on RS is stated on paper but really it can exist only in mind (being a property of an existent object). It is superfluous or double-referential to write it down on paper. For concepts containing actions and with a T in a box in it means that the action can be executed in a specific interpretation J (i.e. in the possible world dictated by interpretation J). For other structures "truth" can mean "existence in a possible world" or whatever the meaning interpreted according to J requires. For propositions like Object-concept-object structures, we have truth being: "the action of the concept can be executed in the possible world dictated by J, using the two objects and both objects exists in the same possible world".

Now we need **SrL** to be compatible with this Metalogical language. This is accomplished just by taking sentences as structures and vice versa. Any "=T" clause can be added to enclosures in a box in the lower right corner of the enclosure.

Ref. [6] exhibits another "proof" of Metalogical MP (it only proves the reasoning is valid, not that it is provable in the logical theory), but it uses the concept of satisfaction and the truth table for "therefore" with its X's not recognised and I don't think that this is correct. It also uses more ideas than the logical proof of ref. [1], therefore

the reasoning is more complex (and requires more tests) than ref. [1]'s proof. Ref. [1] does it with just symbols for structures and two operators.

Ref. [6] also talks about a metalingual variable "o" that evaluates to a number, this is questionable.

We now show how to solve puzzles with **SrL**.

### 2.38 Puzzle

A man who lives on the tenth floor takes the elevator down to the first floor every morning and goes to work. In the evening, when he comes back; on a rainy day, or if there are other people in the elevator, he goes to his floor directly. Otherwise, he goes to the seventh floor and walks up three flights of stairs to his apartment. Can you explain why?

We see that the object "man" just serves as a setting for the puzzle, therefore we model it as the scope of the puzzle. We model conditions like "in the morning" as objects and actions like "moves with elevator down n floors" as concepts.

We strip down the puzzle to its basic elements:

1. In morning, goes to work, moves down with elevator 9 floors.
2. In evening, moves up with elevator 9 floors if it is a rainy day or there are people in the elevator.
3. In evening, moves up with elevator 6 floors, then with stairs up 3 floors if not (it is a rainy day or there are people in the elevator).

Now symbolise this and simplify structure:

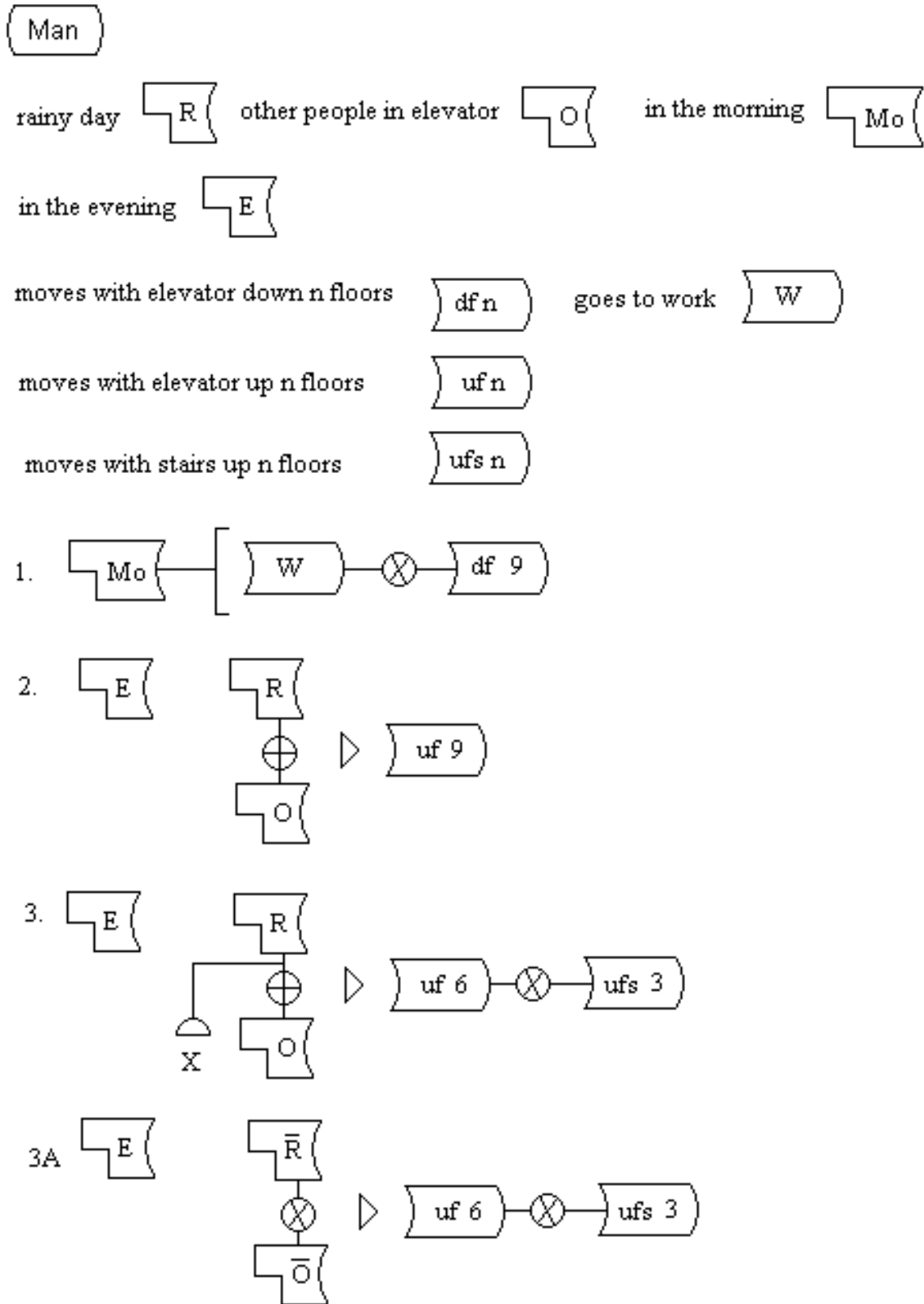

Puzzle Diagram 2.39



where: "df n" is inside a Concept Enclosure. The connective in RS(1) is "logical AND". The connective in (2) represents "logical OR". In (3) we have "not introduction" specified by the Introducer. That (3A) follows from (3) can be proven with a truth table.

Note that  $\sim(R \text{ OR } O)$  translates as:

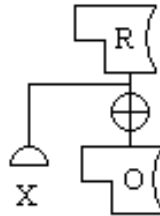

Structure 2.39.1

Also note that in **SrL** we do not need to define operator strength since we can just use the operator precedence operator.

After this (3A) I could immediately see that the first line of the solution is:

1. The steps are outside, the elevator inside, he needs exercise.

Then the question remains: Why don't he do something similar in the morning and why go straight up with the elevator if there are other people in the elevator.

2. In the morning he is hasty and
3. He is shy and do not want the people in the elevator to see his odd behavior.

Then the question remains: why does he not go up with the steps all the way from floor 1 to floor 10 in the evenings.

4. He wants to take the exercise easy.

End Puzzle Solution

Note that the negation in line 3 cannot be stated as: "Not R or Not O", since this means: "some object in anti-scope of R or some object in anti-scope of O".

The following puzzle is a case where "all or nothing" is not the correct way to reason. We state the puzzle first.

**2.40 Puzzle**

Five Cannibals capture three tourists. They are tied to stakes such that they are in a row with the longest in front, shortest at back and the other two looks in the same direction so that the second longest can only see the longest and the other one can see the longest and second longest

The Cannibals give the tourists a chance to go free. They have 2 white hats and 3 black hats. They blindfold the tourists and place some hat on their heads and hide the other hats. Then the blindfolds are taken off.

The back tourist was asked to guess what colour hat he has on. He replies: "I don't know". The middle tourist was asked to guess and he says: "I don't know". The front one reply: "I know!"

How does he know and what colour hat does he have on?

We transform the statements to the basic necessities as follows:

1. Cannibals (5) capture Tourists (3).
2. Cannibals give tourists a chance to escape.
3. The Tourists are tied to a stake such that:

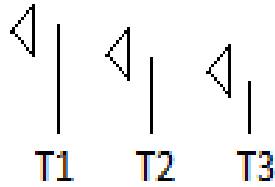

Where the arrows show the direction the Tourists can see in.

4. They have two white hats and three black hats.
5. They place hats on Tourists without Tourists seeing which hats.
6. The Tourists must guess what colour hat he has on.
7. If a Tourist guesses correctly he/they are set free.
8. T3 says: "I don't know", T2 says: "I don't know", T1 says: "I know".

We symbolise this as follows:

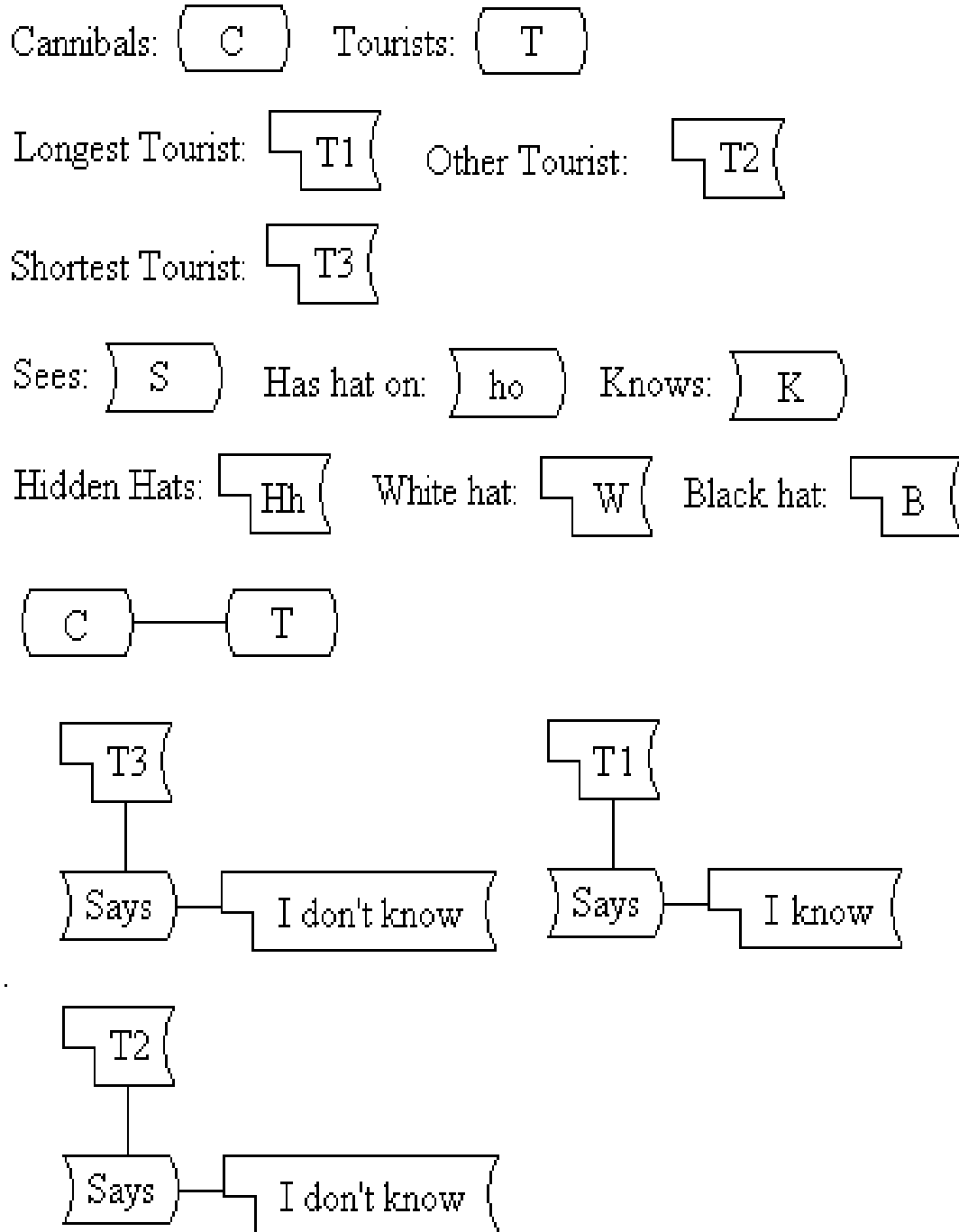

Puzzle Statement 2.40

Line 1, 2 and 3 are the setting of the puzzle.

We give the players and events the designations as in the diagram above.

Note we model "Cannibals relevant to Tourists" as the scope of the puzzle. Then the reasoning goes by cases.

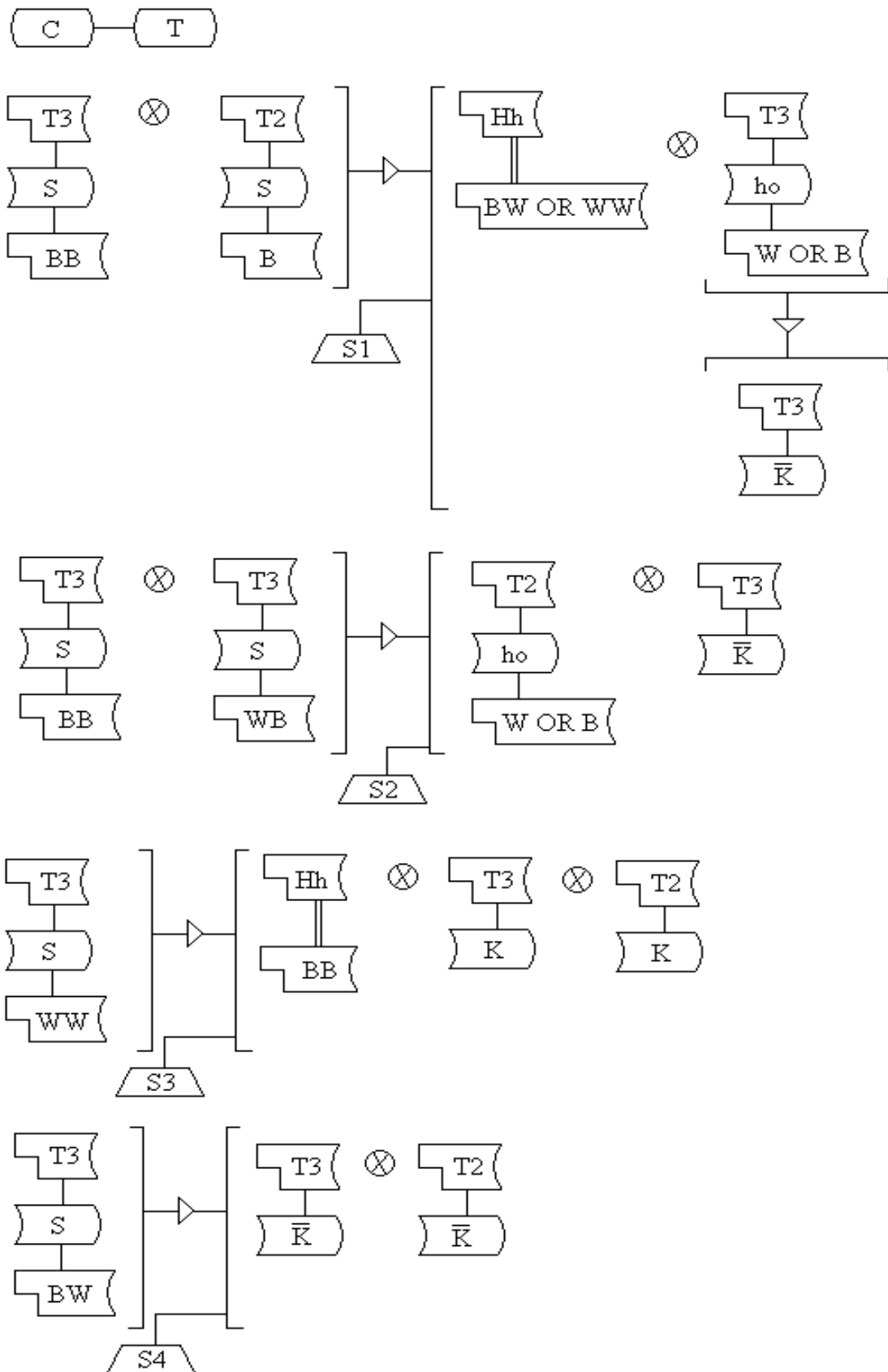

Look how cumbersome the word equivalent of S1 is (no sense of completion of structure):

In line (structure) S1 we suppose T3 sees two black hats and T2 sees a black hat. This means the remaining hats goes to the remaining places: the head of T3 or the hide place. Thus the Hidden hats are (B and W) OR (W and W) and T3 ho W OR B. By S1, T3 does not know what hat he is wearing.

S2 follows by counting and filling empty boxes with B or W. S2 should be understood with AND elimination on left side.

By S1 AND S2 in the cases of LS of S2, both T1 AND T2 does not know (therefore 7 applies)

For S4: T2 knows he is wearing black because he sees (T1 ho W) and he hears T3 ~K (since T3 S WW -> T3 K).

Since all the cases are listed (WW, WB, BW and BB) we can conclude that 7 is false i.e. that (T3 ~K and T2 ~K ~ - > T1 K. Here "~" means "not".

Note that we cannot conclude T1 ho B from negating S3 since there is two possibilities for ((T2 AND T3) ~K) namely BB AND WB.

Since S3 is not the case 7 cannot be true. It could be that I got my Tn's the other way around, in which case T1 ~K, T2 ~K, T3 K i.e. T1 says he don't know, from this and what he sees T2 also says he don't know, but T3 sees two white hats so says he knows.

From the meaning of "such that" the following rule applies:

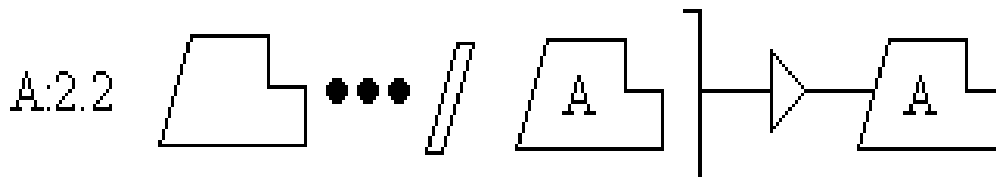

Structure 2.47

Note that LS remains understood and thus remains a (hidden) property of structure A, however structure A can be manipulated separately. If LS gets manipulated it would mean that a property of structure A changes and this can have an influence on A's logic. Also A being true restricts the meaning of the left side of the "such that" symbol.

The following is also obvious:

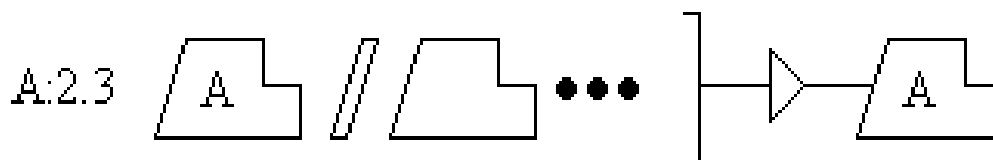

Structure 2.48

Whenever the RS exists.

We now show that reasoning in mathematical terms is a whole lot more messy than what we encountered, even for relatively simple theorems. We use a theorem from ref. [2]. We copy it word for word here for reference. We also

need a Lemma and definition which I found intuitively (with help from a voice). The Lemma is stated without proof:

"2.6 Lemma. Let  $x_0 \in X$ " ( $X$  a metric space) "and let  $\{D_j; j \in J\}$  be a collection of connected subsets of  $X$  such that  $x_0 \in D_j$  for each  $j$  in  $J$ . Then  $D = \text{union of } \{D_j; j \in J\}$  is connected."

"2.7 Theorem. Let  $(X, d)$  be a metric space. Then:  
a) Each  $x_0$  in  $X$  is contained in a component of  $X$ .

*Proof:* (a) Let  $D$  be the collection of connected subsets of  $X$  which contain the given point  $x_0$ . Notice that  $\{x_0\} \in D$  so that  $D \neq \emptyset$  (empty collection). Also notice that the hypothesis of the preceding lemma apply to the collection  $D$ . Hence  $C = \text{union of } \{D: D \in D\}$  is connected and  $x_0 \in C$ . But  $C$  must be a component. In fact, if  $D$  is connected and  $D \cap C$  then  $x_0 \in D$  so that  $D \in D$ ; but then  $D \subset C$ , so that  $C = D$ . Thus  $C$  is maximal and part (a) is proved."

We need the following concepts (I give them special symbols):

collection of sets:   $\overline{D}$

Mathematics

empty collection: 

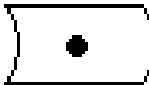
point:   $\overline{x_0}$

connected set: 

"subset of" test operation:  $\subset$

component of a metric space: 

element of:  $\in$

collection is maximal: 

Structure 4.41

We restate the theorem proof in terms of formalised reasoning steps:

1.	$\bigcirc \overline{(X, d)} \uparrow$	assp
2.	$\bigcirc \overline{D} \uparrow // [(\forall \in D) \subset X \otimes ((x_o) \in D // x_o \in X)]$	A(g, -> I)
3.	$\overline{(\forall \in D) \subset X} \otimes ((x_o) \in D // x_o \in X)$	2, irrelevance (A:2.2)
4.	$\{x_o\} \in D // x_o \in X$	3, AND-E $\boxtimes$
5.	$\{x_o\} \in D$	4, irrelevance (A:2.3)
6.	$D \neq \emptyset$	5, $\exists \bigcirc \uparrow$
7.	$\overline{C} = \cup \{D : D \in D\} \otimes x_o \in C$	2, lemma 2.6
8.	$C \subset X \otimes \exists \bigcirc \overline{X} // \neg \uparrow \downarrow \neq C$	2,7 def?
9.	$\overline{C}$	7, immediate
10.	$\overline{C} \otimes C \subset X \otimes \exists \bigcirc \overline{X} // \neg \uparrow \downarrow \neq C$	8,9, AND-I
11.	$C // \neg$	10, immediate
12.	$\bigcirc \overline{D} \uparrow \rightarrow C // \neg$	2-11, -> I $\boxtimes$

Proof 2.42

We use a line to indicate the lines in scope of an auxiliary assumption. The large "!" in line 1 means "exists". The forward slash in line 2 means: "as follows". The A(g, ->I) reason of line 2 means: "auxiliary assumption for purpose of -> introduction". In line 3 the term in the leftmost brackets evaluates to a set and the symbol for connectedness is appended below this. The reason for line 3 i.e. "irrelevance" has to do with the meaning and usage of "such that". Line 3 must be valid for the proof to continue. AND- elimination is used in line 4. I list the properties of a set below the label like in line 7 the set "C" is connected. The question mark in line 8 is because I am not sure about the definition as it does not occur in the ref. The M below the "!" of line 10 make it mean "must exist". The book goes on to prove from line 12 that C is maximal. The reasoning goes: "if A then B so that E ; but then F so that G" and I do not know if "but then" refers to A, B or to E as premise. Note that line 3, 4 and 8 does not occur explicitly in the word proof but I think they are needed as in-between steps.

Look how different this proof is in contrast to structure 2.40.

I struggled to find any more appropriate puzzles (some of them needs hardly one or two symbols). We can try to see if the in between steps using lateral thinking is expressible: it requires thinking across patterns. Since puzzle 2.38 required lateral thinking I will try to express the in between steps as follows:

1. the man needs to climb stairs
2. there could be stairs outside or inside the building
3. it rains outside, not inside the building
- 4 the man needs to climb stairs to get to his house

- 5. a man would want to climb stairs to get exercize
- 6. a man may be shy to let others know he is exercizing.

Now thinking across these six sentences leads to sentence 1 of the puzzle solution.

A book that has interesting implicit understanding puzzles in it is "Ulysses" by James Joyce. On page 1 he writes: " Buck Mulligan peeped an instant under the mirror and then covered the bowl smartly. - Back to barracks, he said sternly."

We analyze this using the symbolisation:

a man: ( M ) Buck: ( B ) ( B )  
 peeped an instant under the mirror: ( P )  
 covered the bowl: ( C )  
 in a smart fasion: ( sf ) smartly: ( S ) the bowl: ( bw )  
 question: ( Q ) behavoir in general: ( B )  
 follows in time: ( F ) causes: ( ca )

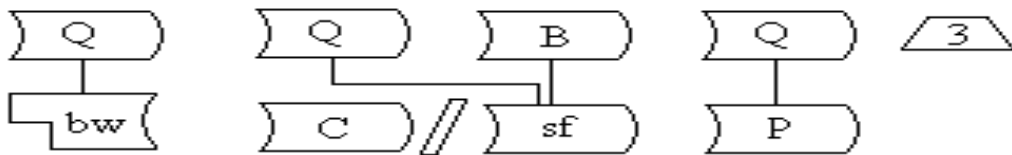
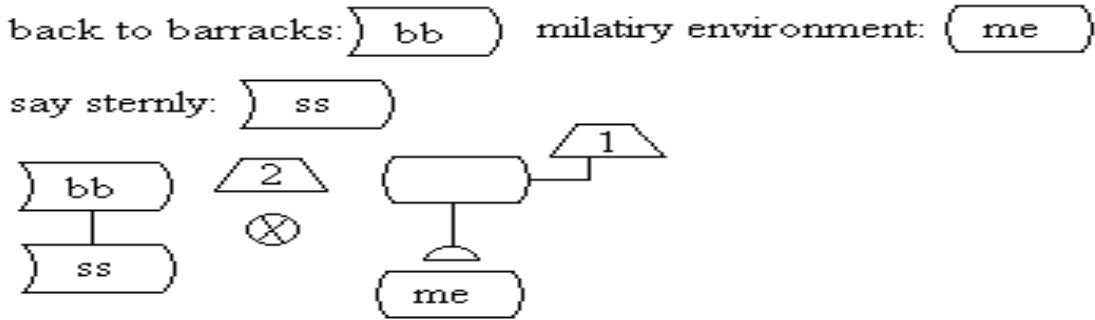
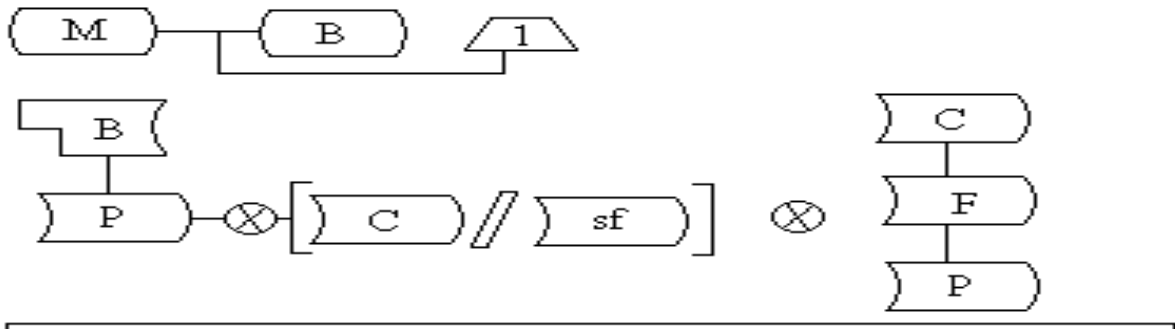

Structure 2.43



Structure 1 and 2 are a symbolisation of the sentences. We need the insight to add the concepts "question" and "behaviour in general" to the symbolisation since this is the key to understanding it.

One might wonder: "what bowl?" or "why cover the bowl?" or "what was in the bowl?" or "why does he cover it smartly?". Structure 3 above covers these questions. "Relevant" can mean "directly relevant". In structure 2 we include the fact that the scope of structure 1 has expanded, just by interpretation of the words "barracks" and "sternly".

These examples indicate how to understand, and this is required for knowledge organisation (as opposed to parrot-style learning).

For mathematical logic we need the ideas of sets and functions. A function maps sets onto sets. Ref. [6] (p.551) has a theorem depending on a definition.

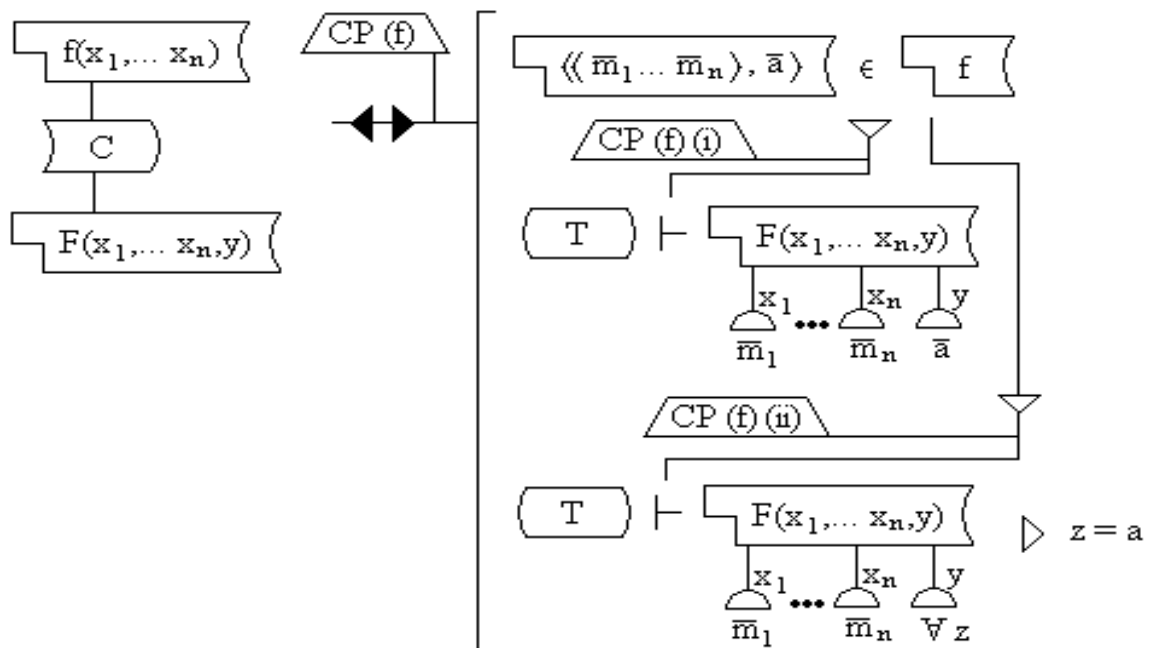
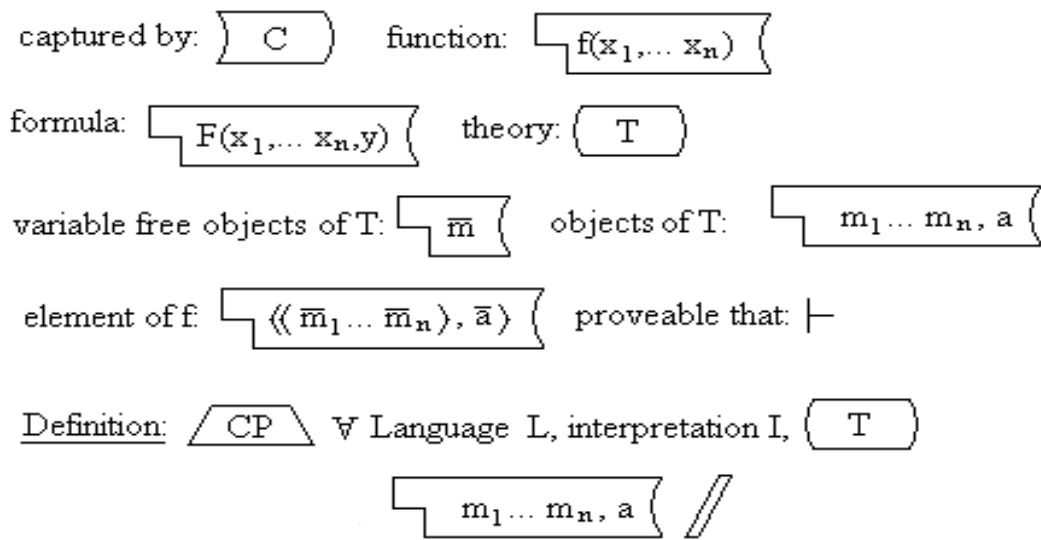

Definition CP.

Note that CP (f) (i) and CP (f) (ii) means the same thing, but it will be shown that we need both statements to reason with.

With the stripe above the F designating negation, the theorem states:

2.44 Theorem

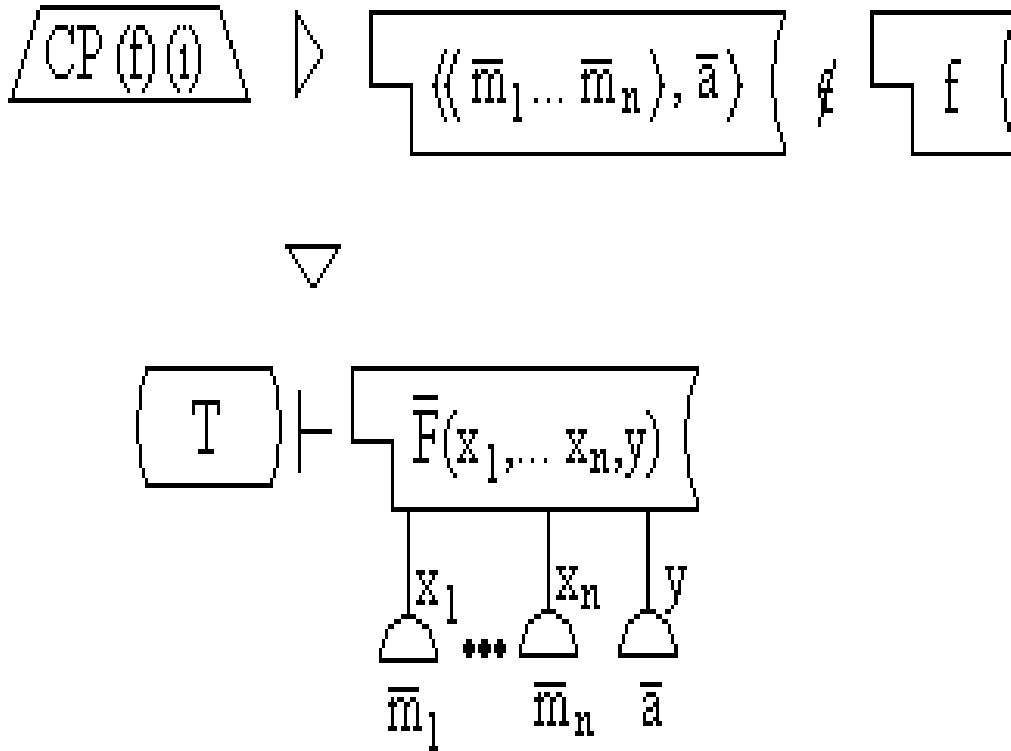

The statement after the bottom "therefore" reads: "It is provable in T that the following formula exists:  $\bar{F}(x_1, \dots, x_n, y)$  with  $\bar{m}_1$  to  $\bar{m}_n$  introduced to  $x_1$  to  $x_n$  and  $\bar{a}$  to  $y$ ."

And the proof goes as follows:

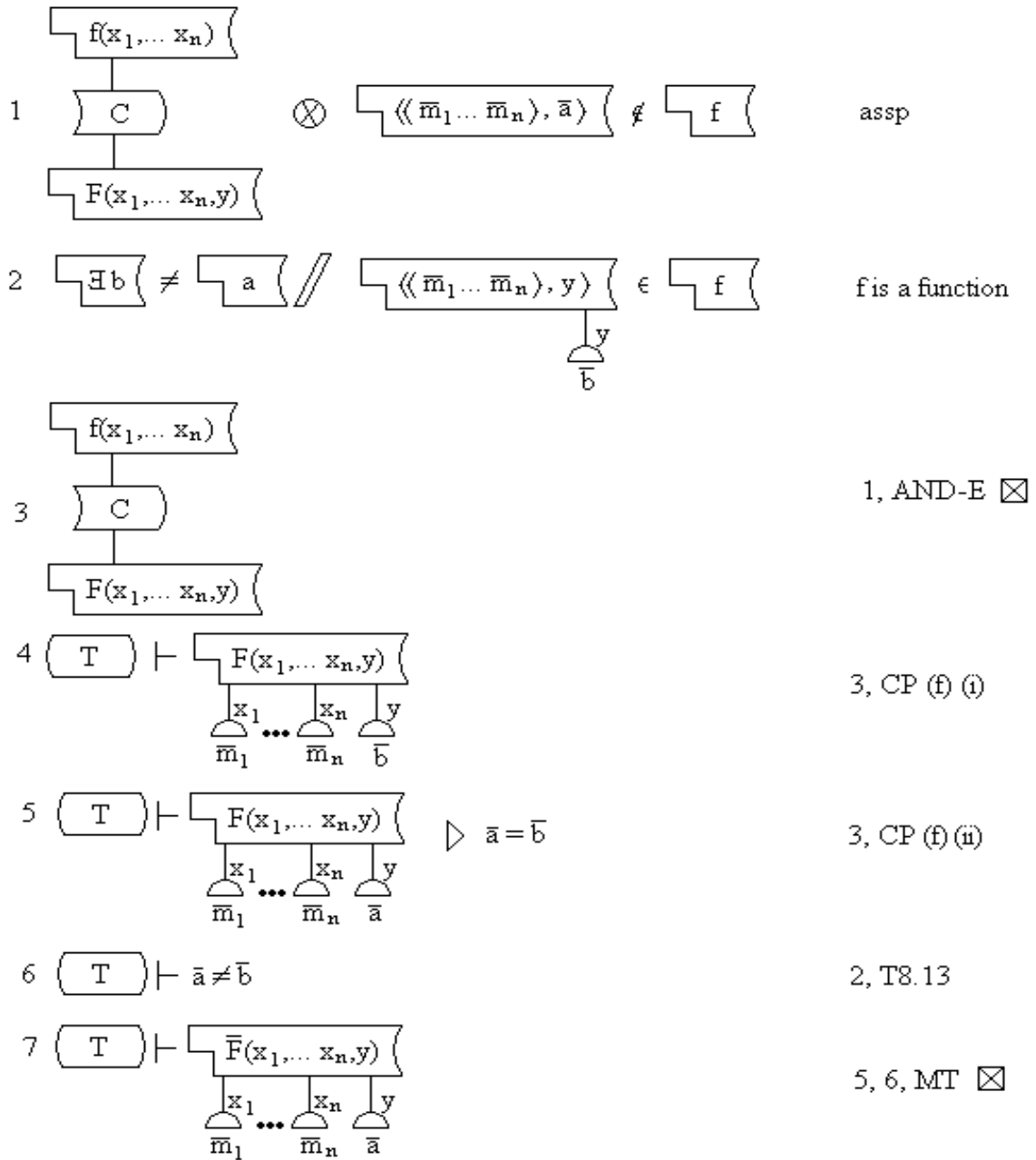

Proof 2.45

Where MT means Modus Tollens (see ref. [1]).

Note that there is some confusion over a stripe above the a and b, "a" means some object a and "a with stripe above" means "a interpreted" amongst others, but since the lines must be interpreted anyway this is no issue. Also note the auxiliary assumption in line 2.

There is another way to negate LS of line 5: "not provable" and not "formula negation is true" but it should be equivalent.

Note from line 7 how well introductors can be used for expressing a variable substitution. The same substitution would be cumbersome in letter logic since it would be reliant on the order of the variables and objects.

The following theorem comes from ref. [6] p. 553 (T13.5). The reader should download ref. [6] in order to compare it with the letter logic version. NB: here we use an Introductor to specify interpretation in the standard interpretation of number theory (N) under variable assignment "d".

**Theorem**

$$\left[ \begin{array}{c} \boxed{s} \\ \downarrow \text{N} \\ \text{d} \end{array} \leq \left[ \begin{array}{c} \boxed{t} \\ \downarrow \text{N} \\ \text{d} \end{array} \right] \right] \rightarrow \boxed{S} \triangleleft \triangleright \left[ \begin{array}{c} \boxed{s} \\ \downarrow \text{N} \\ \text{d} \end{array} \leq \left[ \begin{array}{c} \boxed{t} \\ \downarrow \text{N} \\ \text{d} \end{array} \right] \right]$$

**Proof //**

- 1  $\left[ \begin{array}{c} \boxed{s} \\ \downarrow \text{N} \\ \text{d} \end{array} \leq \left[ \begin{array}{c} \boxed{t} \\ \downarrow \text{N} \\ \text{d} \end{array} \right] \right] \rightarrow \boxed{S}$  assp
  
- 2  $\left[ \exists v + \left[ \begin{array}{c} \boxed{s} \\ \downarrow \text{N} \\ \text{d} \end{array} \right] = \left[ \begin{array}{c} \boxed{t} \\ \downarrow \text{N} \\ \text{d} \end{array} \right] \right] \rightarrow \boxed{S}$  1, abbreviation
  
- 3  $\triangleleft \triangleright \exists m \in \mathbb{U} //$
- 4  $\left[ \begin{array}{c} \boxed{v} \\ \downarrow \text{N} \\ \text{d} \end{array} + \left[ \begin{array}{c} \boxed{s} \\ \downarrow \text{N} \\ \text{d} \end{array} \right] = \left[ \begin{array}{c} \boxed{t} \\ \downarrow \text{N} \\ \text{d} \end{array} \right] \right] \rightarrow \boxed{S}$  SF (E)
  
- 4  $\left[ \begin{array}{c} \boxed{v} \\ \downarrow \text{N} \\ \text{d} \end{array} \right] \text{v} \triangleright \exists m = \boxed{\exists m}$  Interpretation of L  
TA (f)
  
- 5  $\left[ \begin{array}{c} \boxed{v + s = t} \\ \downarrow \text{N} \\ \text{d} \end{array} \right] \rightarrow \boxed{S}$  3, object contraction
  
- 6  $\left[ \begin{array}{c} \boxed{v} \\ \downarrow \text{N} \\ \text{d} \end{array} + \left[ \begin{array}{c} \boxed{s} \\ \downarrow \text{N} \\ \text{d} \end{array} \right] = \left[ \begin{array}{c} \boxed{t} \\ \downarrow \text{N} \\ \text{d} \end{array} \right] \right] \rightarrow \boxed{S}$  5, anti-contraction
  
- 7  $\left[ \boxed{\exists m} + \left[ \begin{array}{c} \boxed{s} \\ \downarrow \text{N} \\ \text{d} \end{array} \right] = \left[ \begin{array}{c} \boxed{t} \\ \downarrow \text{N} \\ \text{d} \end{array} \right] \right] \rightarrow \boxed{S}$  4,6
  
- 8  $\left[ \begin{array}{c} \boxed{s} \\ \downarrow \text{N} \\ \text{d} \end{array} \leq \left[ \begin{array}{c} \boxed{t} \\ \downarrow \text{N} \\ \text{d} \end{array} \right] \right] \rightarrow \boxed{S}$  3, 7, abbreviation

Proof 2.46

Where "SF" and "TA" refers to rules in ref. [6]. Object contraction is valid in the standard interpretation of number theory since the formula of m, s and t defines another object. The concept S means: "is satisfied". In line (3) we have the Introducer specifying "introduce some m into object v".

We see that in the **SrL** version we skip a few steps: we do not need to consider the functions: N[+] and N[=]. Therefore the symbols are more powerful than the letter version. Note how the ref dropped the "= S" without stating a reason. The concept S can be dropped in line 8, since it is understood. The reasoning in the R to L direction of the theorem is not stated but would use object contraction and anti-contraction.

It seems like we cannot get away from having to specify a lot of rules even for simple reasoning. I think there is a lot more rules since there are many concepts with meanings in ordinary language.

We need to model meaning with operators included. All we need for this is a mesh of slots accepting ideas. Then operators are "things" that move ideas relative to the mesh and other ideas.

Now Wisdom can be defined as a process making new slots for ideas and then using them. In Plato's Republic (ref. [8], p. 250) he talks about the visible and the intelligible in a geometric language. The following structure is what I think he means:

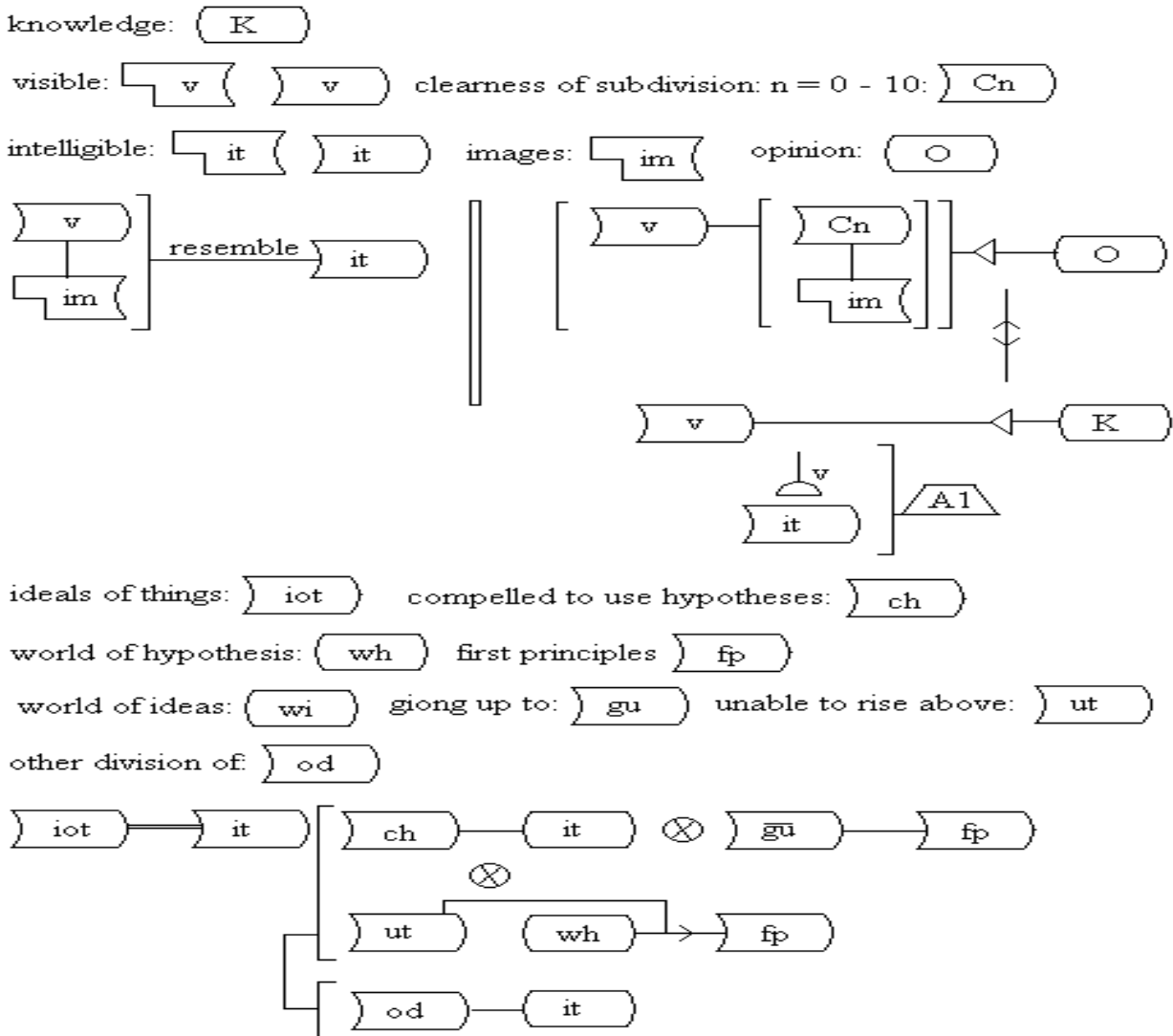

Structure 2.49

Now consider what the operation A1 would necessitate the right structure to transform into. Note how this enhances the meaning and how it creates new possibilities.

We adopt the (slightly altered) definition of ref. [6] for validity.

**2.50 Definition**

An argument is logically valid iff there is no consistent (meaningful) story such that the premises are true and the conclusions are not. There must be a reason (provable or axiomatic) to move from the premises to the conclusion.

This is what I got out of ref. [7]. My own ideas are included.

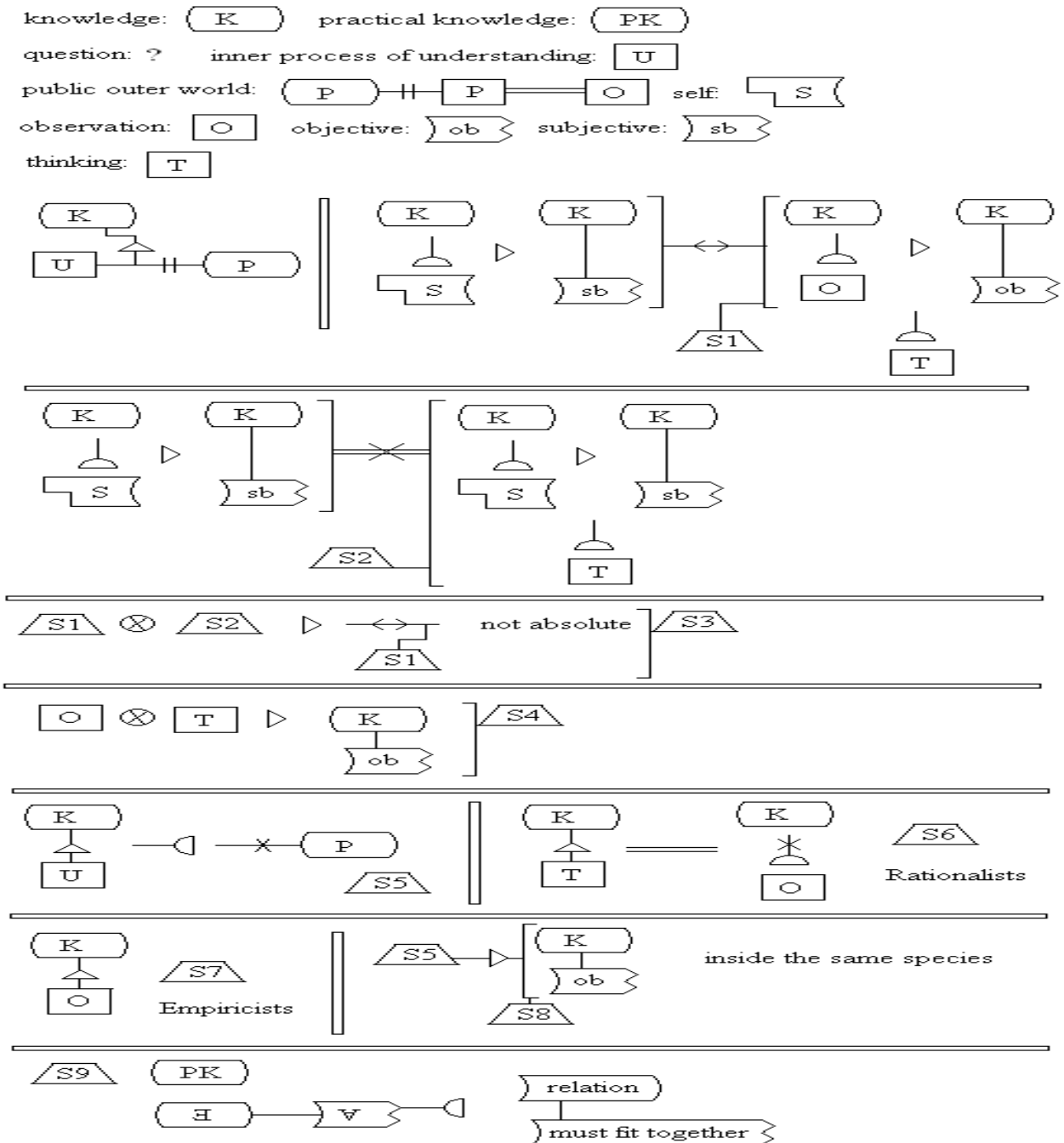

Structure 2.60

Note that we can now define as many (theoretical) types of knowledge as we need. In words S3 says that since S1 and S2 applies the relation "set against" of structure S1 is not absolute, i.e. LS and RS of S1 may share the same idea(s). S4 follows directly from RS of S1. Knowledge of type S6 is such that no observational data influenced it. I certainly have information resulting from fantasies and it can be used in the real world, so I reason that this type of knowledge can exist. Whether ideas of mathematics are all S6 is questionable, because the interpretation of numbers of objects is included inside the symbolism.

I can prove that there are S6 type knowledge in my mind, by proving it was produced by thought-waves and that the structures required existed in my brain before there was any visual input of the public world. However it uses pictures of the actual nervous system and it is difficult to externalise.

Russell and Hume denied the existence of knowledge type S7 (empirical knowledge). I don't agree since a process must exist and a process consists of logical steps (in some computer). Claims to knowledge of this kind is probable since the general movement of people making A connect with B is the same for everyone in the same building (anyone will access the same building by the same enterences). Moreover we agree on matters under various scopes, except for contravercial issues which generate the most discussions. Nature is forgiving as we might see from Newtonian mechanics v.s. Einsteinian mechanics.

S8 says that S5-type knowledge can be considered objective for members of the same species since we agree on many states of affairs and since our brains are anatomically similar.

S9 defines "Practical Knowledge", PK or the ideas that must string together in order to enable someone to manipulate in the physical realm. Here the only relation is "must fit together" (for now). If the reader does not agree with this please prove me wrong. I am saying that all of this knowledge can be reduced to using only ideas and this relation.

We have the following:

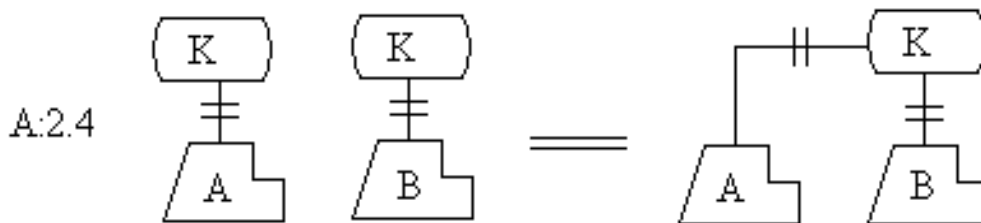

Structure 2.61

and in any general case where we have structures or enclosures have some relation with the same scope enclosure the scope enclosures collapse onto any one of it's ocurrences. This agrees with our intuition on "subject matter". The LS meaning "and the two structures exist together" disappears, but this could also disappear by AND-Elimination. We therefore see that logically equivalent transformations do NOT preserve meaning but can discard some meaning. However elimination of irrelevant or superfluous meaning seem to be required of classical reasoning. In any case I saw that some discussions in books have relevance shifts to different scopes so that some meaning fits in one structure with other meanings in another. There could then be a reference to the other structure if the maker of the structure decides so.

Berkeley argued that effects must always be of the same general nature as their causes. I think this is in error. I think the spirit cannot influence matter, but can influence physical energy to some minute extent. It is this energy that can in turn effect ions in the mind and therefore single nerve cells. This means there can be causation across the mind-body bridge. This view deals simultaneously, in a positive fashion, with the problem of personal responsibility and the existence of God.

Causation can always be removed from a statement (since it has "therefore" in its meaning), and can be said to creep back in on introducing some interpretation to the statement. For example: John opened the door and Pete opened a door. From a "the door"-oriented interpretation we have "John causing the door to open and Pete may

have opened the same door" which is contradictory so we conclude there must be two doors for both to open. But we have a "the door"-interpretation so there are not two doors. This is a paradox.

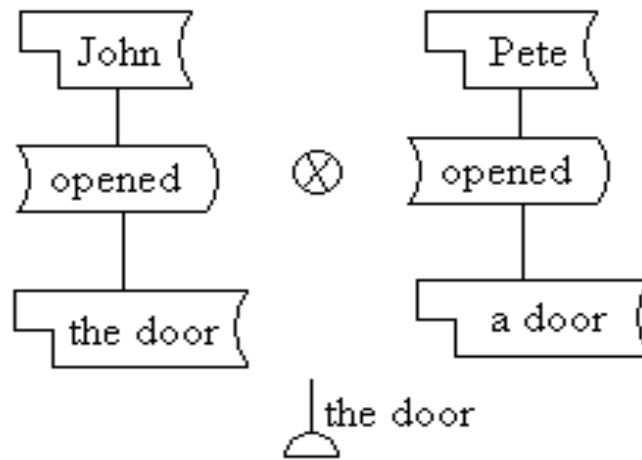

Structure 2.62

We see that we derived a contradiction from the same premise. So where have we gone wrong? It was in assuming the possible world has only one door. So what in the world is there only one of? The self! Therefore we have that causation and self-reference together (may) lead to a paradox or we can state it as: specification together with self-reference (may) lead to a paradox. Now consider what this paragraph states!

We deal with humor differently than ordinary CL. Take the saying "All that glitters is not gold". On face value one can say in other words: "All that glitters is something else than gold", but the saying is meant humorously so we **understand** it to mean: "don't fool yourself by thinking: "if it glitters then it is gold."". So the transformers: "is a saying" coupled with "is meant humorously" impels us to search for a wise saying which is "humorously implied" by the saying, and the following is meant by the saying:

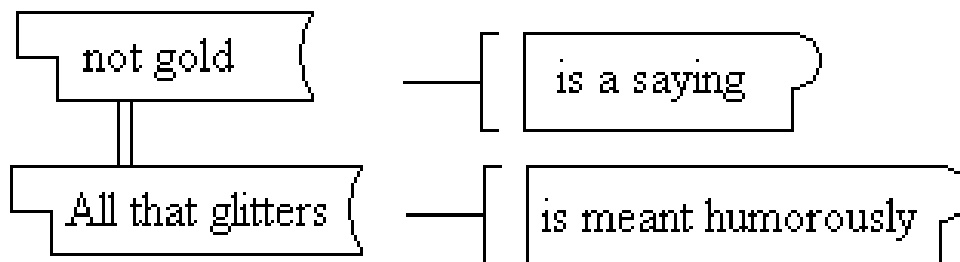

The right enclosures codes for: "proposition".

So humor is logic with some logical quirk.

We now show how to solve a relatively simple puzzle.

**Puzzle 2.63: The Artisans**

There are three men, John, Jack and Joe, each of whom is engaged in two occupations. Their occupations classify each of them as two of the following: chauffeur, bootlegger, musician, painter, gardener and barber.

From the following facts find in what two occupations each man is engaged:

1. The chauffeur offended the musician by laughing at his long hair.
2. Both the musician and the gardener used to go fishing with John



3. The painter bought a quart of gin from the bootlegger
4. The chauffeur courted the painter's sister
5. Jack owed the gardener \$5
6. Joe beat both Jack and the painter at quoits.

Reduced to its essentials in the interpretation we have the sentences above amounting to those in the following structure. The structure shows just how simple the puzzle is.

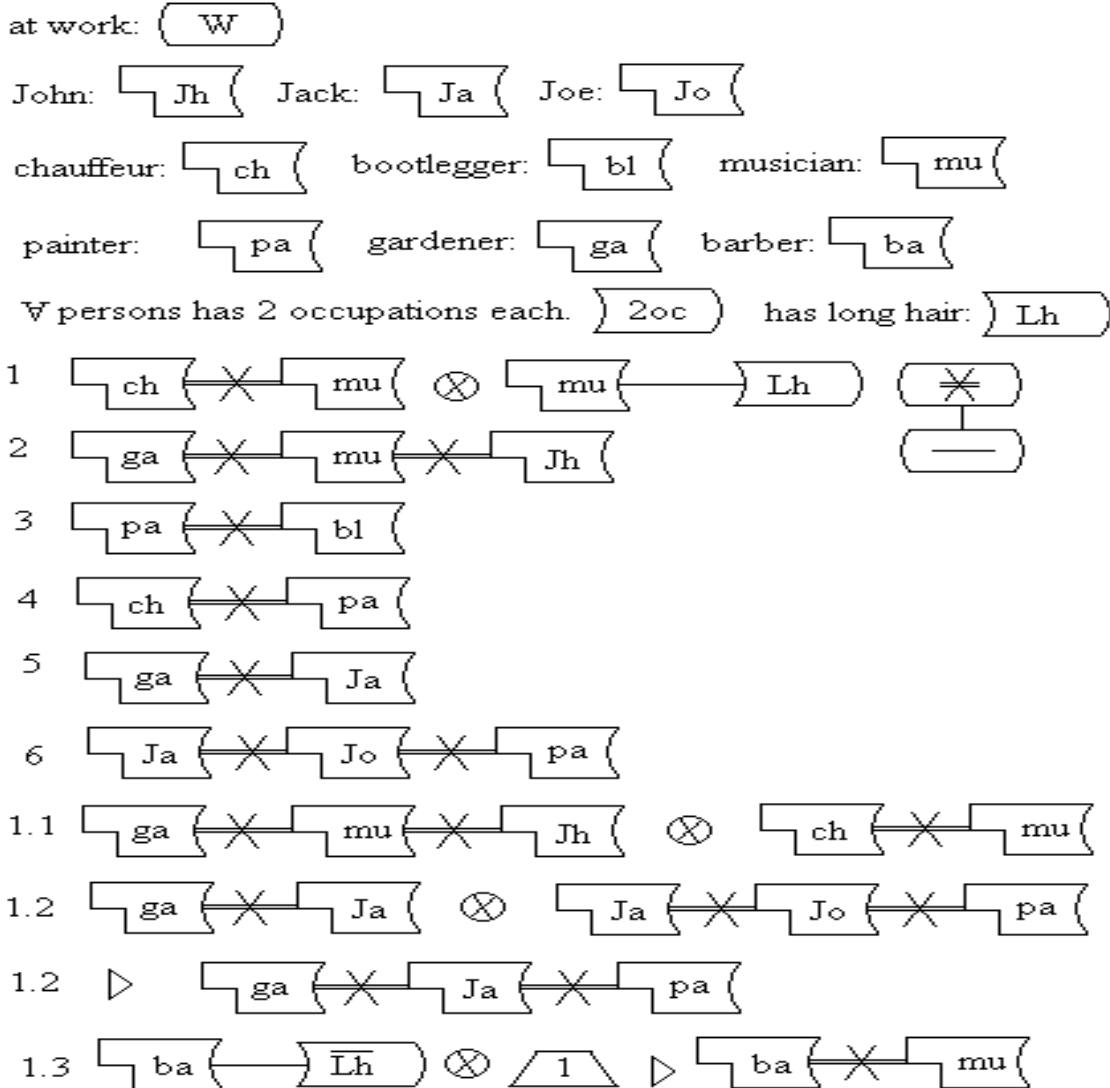

	ga	mu	ch	pa	bl	ba
Jh	x		x	o	x	
Ja	x			x		
Jo				x		
ga		x		x		
mu						x
ch		x		x		
pa						
bl				x		
ba		x				

	ga	mu	ch	pa	bl	ba
Jh	x	cx	x	o	x	co
Ja	x	so	cx	x	co	cx
Jo		cx		x	cx	cx
ga		x		x		
mu						x
ch		x		x		
pa						
bl				x		
ba		x				

The left grid is what can be filled in immediately from 1 to 1.3. The right grid shows the progress after we made the test assumption that Ja is mu. "so" means supposed yes, "co" means consequent yes, "cx" means consequent no. Note that in the "translations" we worked towards non-equivalence and we stated this as the ruling relation in the scope enclosure. After grid 2 it remains to check if "Jo is ga" and "Jo is ch" is consistent with the clues 1 to 1.3. If they are we can be certain of the solution since for all the persons it would be determined what work they do.

We state another (more complex) theorem from ref. [2], and symbolise and formalise the proof. The letter version left out the way to prove line 1 is equivalent to the proof. The theorem shows nicely how a statement in mathematics can be equivalent to another totally different one (see line 1 and compare it to the statement of the theorem). In the following all letters and symbols with letter names are concepts and all other symbols are relations. A concept can reduce to a letter name of a number.

topological space:  $\begin{matrix} \oplus \\ \oplus \\ \oplus \\ \oplus \end{matrix} \Big|_{X, F} \longleftrightarrow \bigcirc \Big|_X \otimes \bigcirc \Big|_F \Big/ \forall \epsilon \in F = \langle \bigcirc \rangle \subseteq X$   
 Hausdorff space:  $\begin{matrix} \oplus \\ \oplus \\ \oplus \\ \oplus \\ H \end{matrix}$   
 compact space:  $\begin{matrix} \oplus \\ \oplus \\ \oplus \\ \oplus \\ \circ \end{matrix}$  show:  $\bigcirc -$

**Theorem**

$$\begin{matrix} \oplus \\ \oplus \\ \oplus \\ \oplus \\ H \end{matrix} \Big|_{X, F} \otimes Y \subseteq X \otimes \begin{matrix} \oplus \\ \oplus \\ \oplus \\ \oplus \\ \circ \end{matrix} \Big|_{Y, G} \Big] \triangleright \langle \bigcirc \rangle \Big|_Y$$

**Proof:**

$$1 \quad \left[ \forall a \in \bigcirc \Big|_{X - Y} \right] \triangleright \exists \langle \bigcirc \rangle \Big|_U \Big/ a \in U \otimes U \cap Y = \emptyset \quad \text{Assumption}$$

$\bigcirc - 1 \triangleright$  **Theorem**

- |    |   |   |
|----|---|---|
| 2  | $a \in U \otimes U \cap Y = \emptyset$ or all a in U are not in Y                   | 1, irrelevance  |
| 3  | a really just in X - Y and U  | 2, 1 LS   |
| 4  | $Y \subset X$   | 1, a exists in U  |
| 5  | $U \subseteq (X - Y)$   | 3   |
| 6  | $\langle \bigcirc \rangle \Big _U$  | 1, X open and closed  |
| 7  | $\bigcirc \Big _H \leftarrow \langle \bigcirc \rangle \Big _U =$ topology of X - Y  | 5, 6, def. $\begin{matrix} \oplus \\ \oplus \\ \oplus \\ \oplus \end{matrix}$ |
| 8  | $\begin{matrix} \oplus \\ \oplus \\ \oplus \\ \oplus \end{matrix} \Big _{X - Y, H}$ | 7, immediate  |
| 9  | $\bigcup_i U_i \in H = Y$   | 4, 8, 5   |
| 10 | $\langle \bigcirc \rangle \Big _{\bigcup_i U_i \in H}$                              | 7 U open is open  |
| 11 | $\langle \bigcirc \rangle \Big _Y$  | 9, 10 complement of open set  |

12  $\exists a \in (X - Y)$  Assumption

$$13 \quad \left[ \forall y \in Y \langle \bigcirc \rangle \Big|_{U_y} \otimes \langle \bigcirc \rangle \Big|_{V_y} \subset X \Big/ a \in U_y, y \in V_y \otimes U_y \cap V_y = \emptyset \right] \quad 12, \begin{matrix} \oplus \\ \oplus \\ \oplus \\ \oplus \\ H \end{matrix} \Big|_{X, F}$$

14  $\{V_y \cap Y : y \in Y\} = \langle \bigcirc \rangle \in G \Big] \text{ covers } Y$  13

15  $\exists y_1, \dots, y_n \in Y \Big/ Y \subset \bigcup_{i=1}^n (V_{y_i} \cap Y) \subset \bigcup_{i=1}^n V_{y_i} = V$  14, Y compact

16  $\forall i \Big/ a \in U = \bigcap_{i=1}^n U_{y_i} \in F$   $a \in U_{y_i}, U$  is not a point

17  $U \cap V = \bigcup_{i=1}^n U \cap V_{y_i} = \emptyset$  13, 16

18  $U \cap Y = \emptyset$  14, 17, 15

Line 7 reads: "open set U get imported into collection of sets "H" and this forms a topology on X-Y".

Line 1 of the structure contains the definition of a topological space. "Logically equivalent to" and "equal to" uses the same symbol, but it should be clear from the context.

Line one has a line in the statement from a to the open set U. This is read as: "all a is connected to some open set U" which implies (by just a stretch of the underlay of the concept "connected to") that "for all a there is a open set U". This is accomplished by considering the idea of "connected to" as somewhat fuzzy.

The mathematician who proved this theorem must have done line 2 to 11 in his mind. The longest line in these is line 7.

I've read that mathematicians use CL and good taste. The "good taste" part is what we will attempt to capture as well. Structure 2.64 certainly makes a dent on this since there was steps (lines 2-11) left out that got discovered by our neater symbology.

The following defines more symbols for ideas from mathematics.

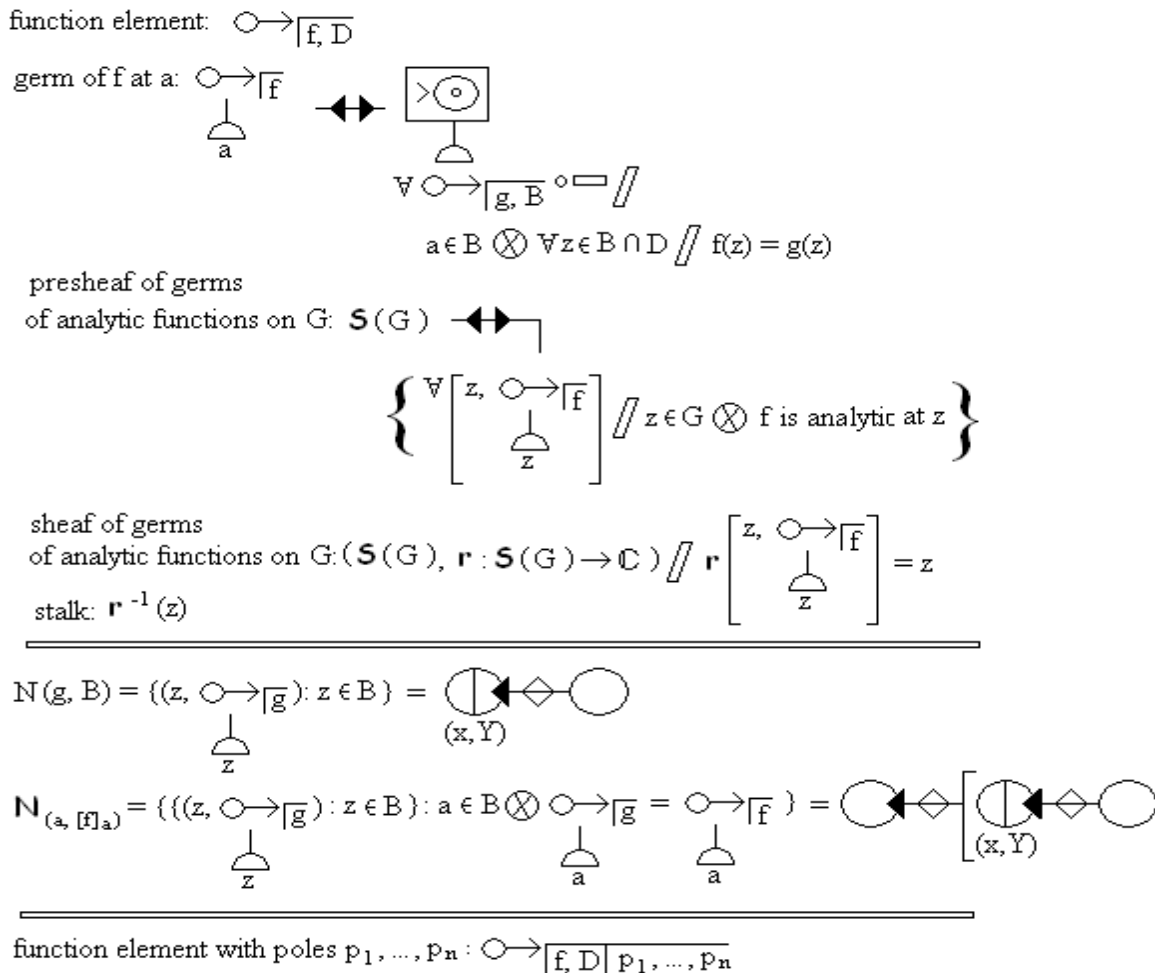

Structure 2.65.1

Note that I keep this symbolization (the Introductors) because it reminds of the complexity of the construction. The letter version makes it look overly simple. The circle and stripe means "more than one". The circle with the stripe in the middle is a two-dimensional set. The ref calls the germ of f at a as [f] subscript a. The reason that the domains of the function elements can be left out (if the reader looks at the definition) is since "B intersection D"

occurs in it and since B is a dummy domain; "B intersection D" is a dummy domain, so that the terminology rightly leaves D out.

I do not know what the intention was with the terminology of  $N(a, [f]a)$ , but to me the terminology looks wrong since the quantified element is  $(g, B)$  or  $g$  and  $a$  (the ref. does not manipulate the indices of this set of sets). That way the function  $g$  becomes hidden and ignored. The last function element with poles is my idea. The germ of  $f$  at  $a$  is a collection of function elements (as the process states) generated by dummy functions  $g$  on dummy domains  $B$ .

The set  $N(g, B)$  works as follows: If

$$\left[ \begin{array}{c} b, \text{ } \circ \rightarrow |h \\ \text{ } \cup \\ \text{ } b \end{array} \right] \in \left\{ \begin{array}{c} \text{ } z \text{ } \otimes \text{ } \text{ } \circ \rightarrow |g_1 \\ \text{ } \cup \\ \text{ } z \end{array} \right\} // \left\{ \text{ } z \text{ } \in \text{ } \textcircled{B_1} \right\} \cap$$

$$\left\{ \begin{array}{c} \text{ } z \text{ } \otimes \text{ } \text{ } \circ \rightarrow |g_2 \\ \text{ } \cup \\ \text{ } z \end{array} \right\} // \left\{ \text{ } z \text{ } \in \text{ } \textcircled{B_2} \right\}$$

Structure 2.65.2

Then we can substitute  $b$  for  $z$  in RS to obtain:

$$\left\{ \begin{array}{c} \text{ } z \text{ } \otimes \text{ } \text{ } \circ \rightarrow |g_1 \\ \text{ } \cup \\ \text{ } z \end{array} \right\} // \left\{ \text{ } z \text{ } \in \text{ } \textcircled{B_1} \right\} \cap$$

$$\left\{ \begin{array}{c} \text{ } z \text{ } \otimes \text{ } \text{ } \circ \rightarrow |g_2 \\ \text{ } \cup \\ \text{ } z \end{array} \right\} // \left\{ \text{ } z \text{ } \in \text{ } \textcircled{B_2} \right\} \xrightarrow{z \cup b}$$

$$\nabla$$

$$\left\{ \begin{array}{c} \text{ } b \text{ } \otimes \text{ } \text{ } \circ \rightarrow |g_1 \\ \text{ } \cup \\ \text{ } b \end{array} \right\} // \left\{ \text{ } b \text{ } \in \text{ } \textcircled{B_1} \right\} \cap$$

$$\left\{ \begin{array}{c} \text{ } b \text{ } \otimes \text{ } \text{ } \circ \rightarrow |g_2 \\ \text{ } \cup \\ \text{ } b \end{array} \right\}$$

$$\nabla$$

$$b \in \textcircled{B_1} \cap \textcircled{B_2}$$

Structure 2.65.3

By taking apart the 2-dimensional set.

Now the terminology allows us to conclude also that:

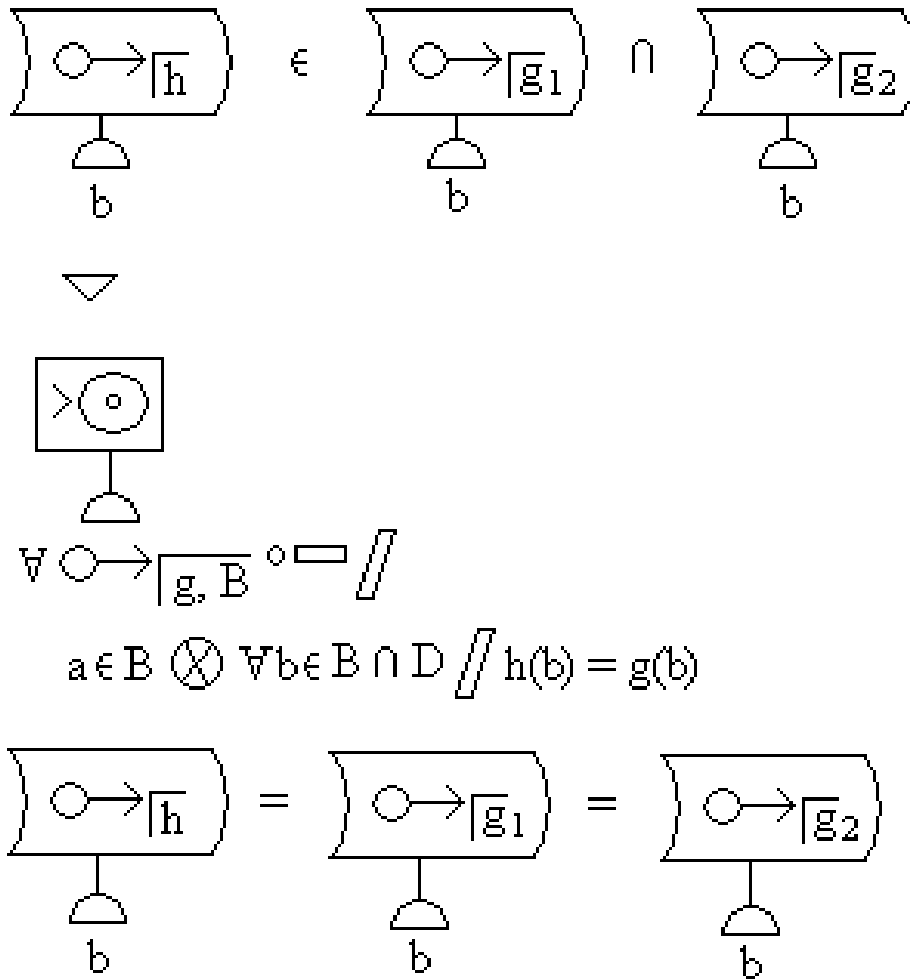

Structure 2.65.4

but this is because the "element of" and "intersection of" relation becomes "=" by abuse of terminology. We do not interpret the symbols above as numbers (they are sets) but the above won't follow for any general sets.

It seldom happens that we interpret sets into the real world; rather the set definition will be used to find a specific member of a set, which we then attribute to some quantity. We can talk about "the books" or "the children on the playing field" but somehow my mind tells me these are just what it says and not sets. You need to move up one level in reasoning to abstract them into sets. Thus there is a level of "inexpressible" reasoning on the level of "what-it-is" and these are double referential if it gets expressed. The idea of "number" is on this level. We name this "level 1". This is why we specify an interpretation on a logical language. A computer will tell you only numbers are on this level. I think that the essence of objects, symbols and the like are also on this level.

The **second level** of reasoning is the "what-is-the-relationship" level. This is the level of sets, relations, functions and the like. The **third level** is "about level 2". Symbolising about how we move again from level 3 to level 1 could be said to be a **fourth level**. I would term it the 3-to-1 level and similarly for the 2-to-1 level. Ref [6] also has rules to go from level 3 to level 2, though this is not called "interpretation".

We can now define the idea "abstraction" exactly as: take objects of level 1 and make a representation(s) of them on level 2. Or just as: move up one level of reasoning. Then "interpretation" or "specification" is the inverse operation (level 2-to-1).

I ran the idea of a collection of sets of sets through my logic analyser and it produced the thought "contradiction" and irrationally a list.

We work towards the concepts related to Analytic Covering Maps. These are pairs consisting of a Topological Space together with an analytic function with certain properties. From here I continue to reason towards Covering Maps of functions with poles.

In ref [2] they state that  $\{N : x \text{ in } X\}$ , where  $N$  is a collection of sets, induces a topology on  $X$ . Now  $F$  (the topology on  $X$ ) is a collection. So "induce the original topology" must mean: "take some collection out of the set  $\{N : x \text{ in } X\}$ , then the sets coincide in structure to those of  $F$ ".

**Appendix A: Operator List.**

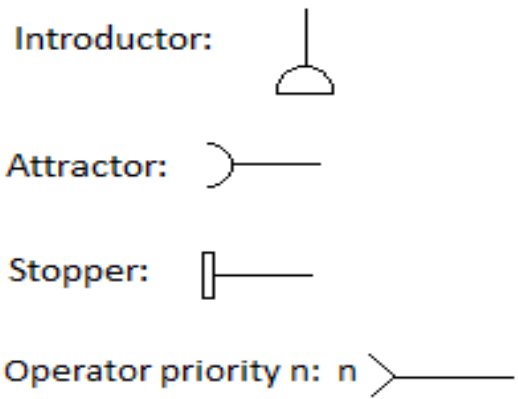

**Appendix B: Relation List.**

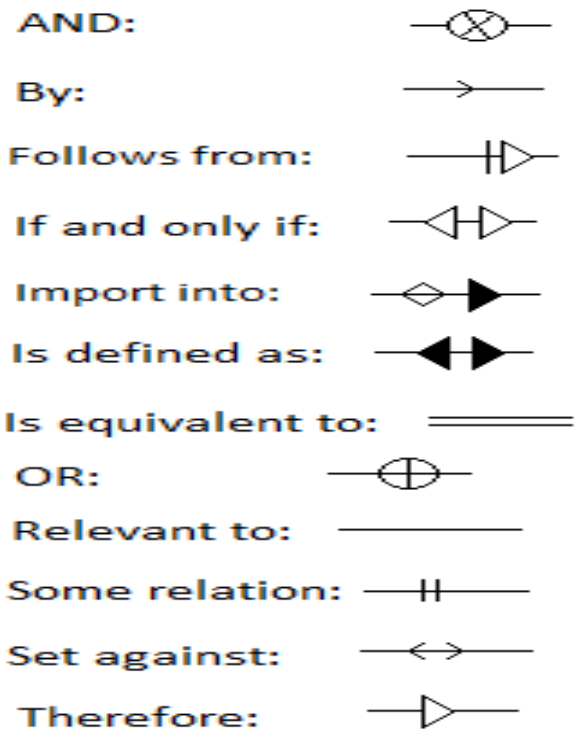

Appendix C: Enclosure List.

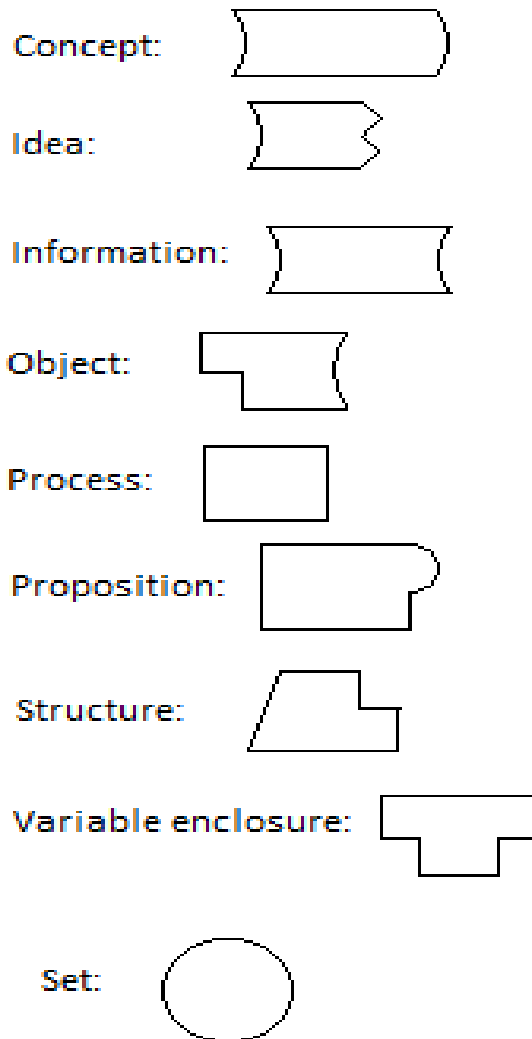

Conclusion: we conclude that SrL is usefull in a variety of settings.

Compliance with Ethical Standards:

Funding: The writer did not receive any funding.

Ethical approval: This article does not contain any studies with human participants or animals performed by any of the authors.

**Bibliography.**

1. W. F. Esterhuyse, Introduction to Logical Structures, Scribd. 2012.
2. S. K. Langer, An Introduction to Symbolic Logic, Dover Publications, 2011
3. T. Button, Level Theory, Part 1: Axiomatizing the Bare Idea of a Cumulative Hierarchy of Sets. The Bulletin of Symbolic Logic. Cambridge. 2021. DOI: 10.1017/bsl.2021.13.
4. F. P. Schuler. The Geometric Anatomy of Theoretical Physics. Internet. 2015
5. H.O. van Rooyen. Relation Nets in Learning and Teaching: A Knowledge Representation Approach. Academia. Internet. Undated.